

CITY OF BEACON PRIVATE ROAD SECTION
SCALE: NOT TO SCALE

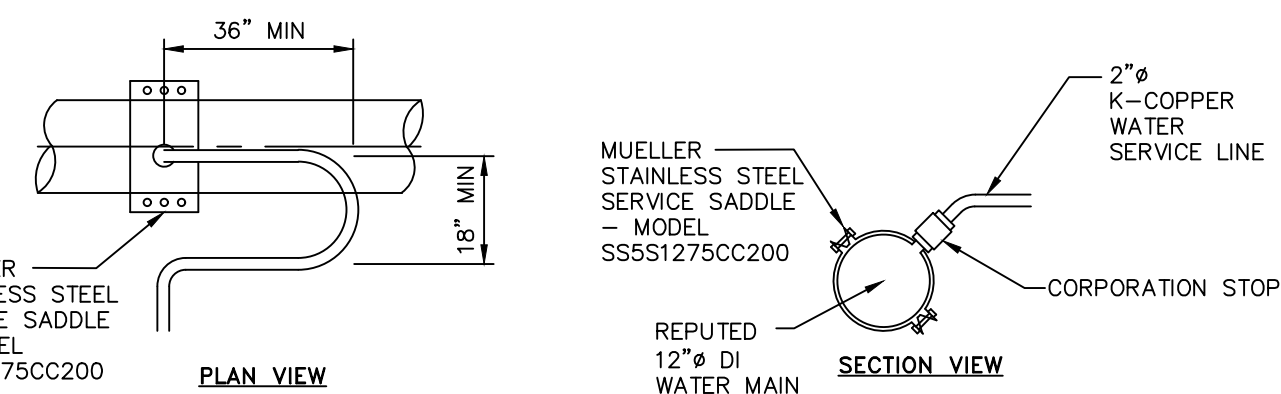

NOTES:
 1. A MINIMUM 5' COVER SHALL BE PROVIDED ON THE WATER SERVICE LINE (CONDITIONED ON ACTUAL WATER MAIN DEPTH).
 2. CORPORATION STOP TO BE COMPRESSION TYPE BY MUELLER.
 3. WATER SERVICE LINE TO HAVE A 'GOOSENECK' NEAR CORPORATION STOP.
 4. CORPORATION STOP TO BE INSTALLED IN THE UPPER HALF OF THE WATER MAIN AT AN ANGLE OF APPROXIMATELY 45° FROM HORIZONTAL.
 5. THE CONTRACTOR SHALL INSTALL A FULL BODIED STAINLESS STEEL TAPPING SLEEVE AT THE PROPOSED WATER SERVICE LOCATION.

WATER SERVICE CONNECTION DETAIL
NOT TO SCALE

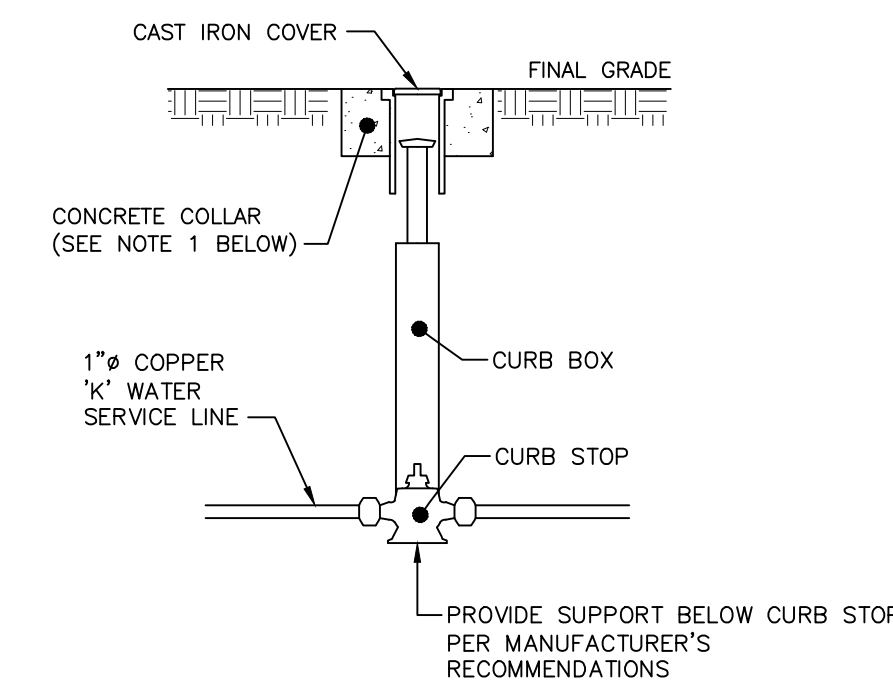

NOTES:
 1. CONCRETE COLLAR TO BE PROVIDED IN AREAS THAT ARE NOT PAVED. THE COLLAR SHALL BE 6" FROM THE COVER AND SHALL EXTEND 6" BELOW FINAL GRADE.
 2. CURB STOP TO BE COMPRESSION TYPE BY MUELLER.
 3. AREA AROUND CURB BOX TO BE FILLED WITH GRAVELLY MATERIAL.

WATER SHUT-OFF VALVE DETAIL
NOT TO SCALE

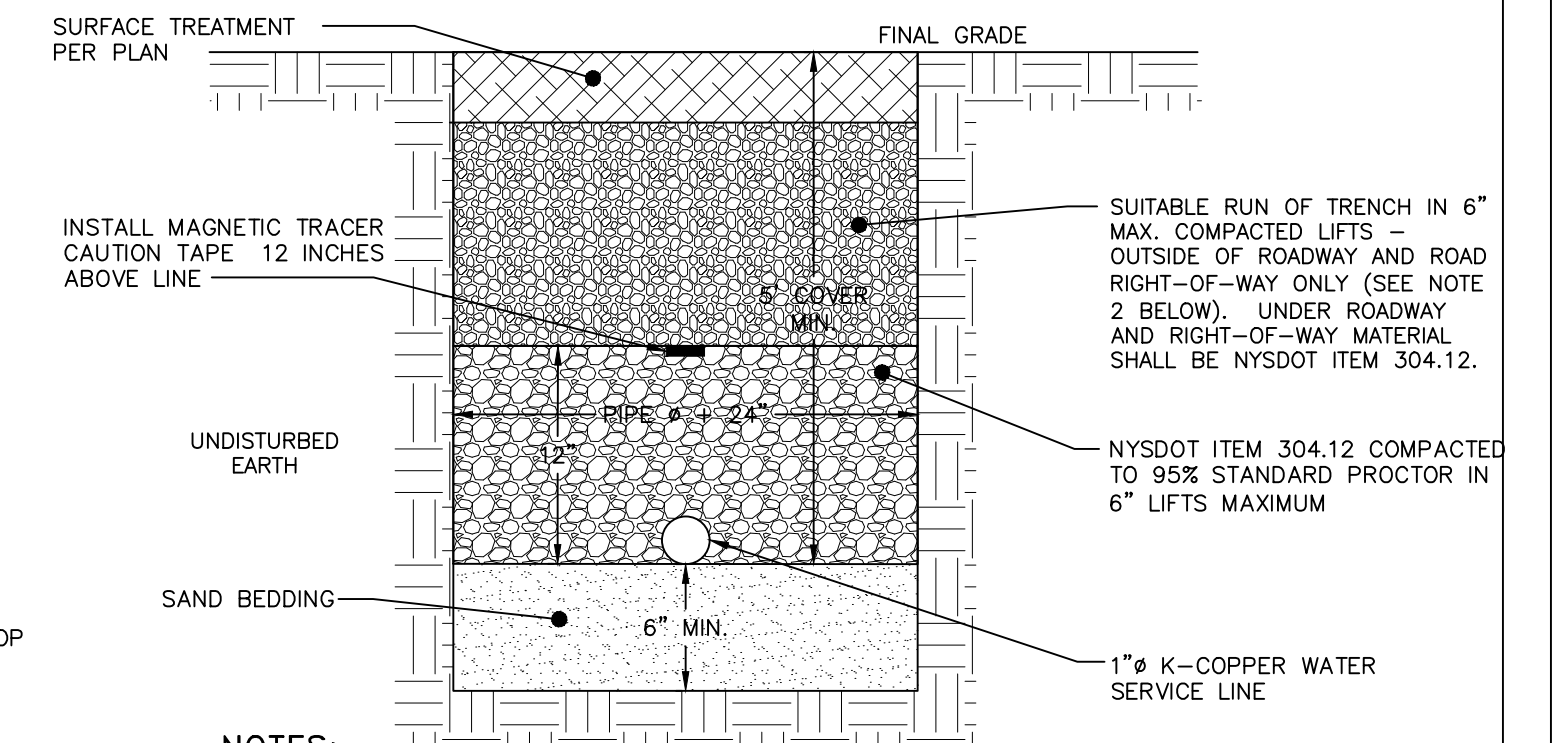

NOTES:
 1. EXCAVATION AND TRENCHING SHALL MEET ALL OSHA REQUIREMENTS.
 2. SUITABLE RUN OF TRENCH SHALL NOT INCLUDE FROZEN MATERIALS, DEBRIS, ORGANIC MATERIALS, ENLARGED PARTICLES, LARGE STONES OR OTHER UNSUITABLE MATERIALS. IF THE RUN OF TRENCH MATERIAL IS FOUND TO BE UNSUITABLE, A SUITABLE BACKFILL MATERIAL SHALL BE IMPORTED AND USED.
 3. IN AREAS WHERE 5' COVER REQUIREMENT CANNOT BE MET, THE CONTRACTOR SHALL PROVIDE PIPE INSULATION TO PREVENT FREEZING.

WATER SERVICE LINE TRENCH DETAIL
NOT TO SCALE

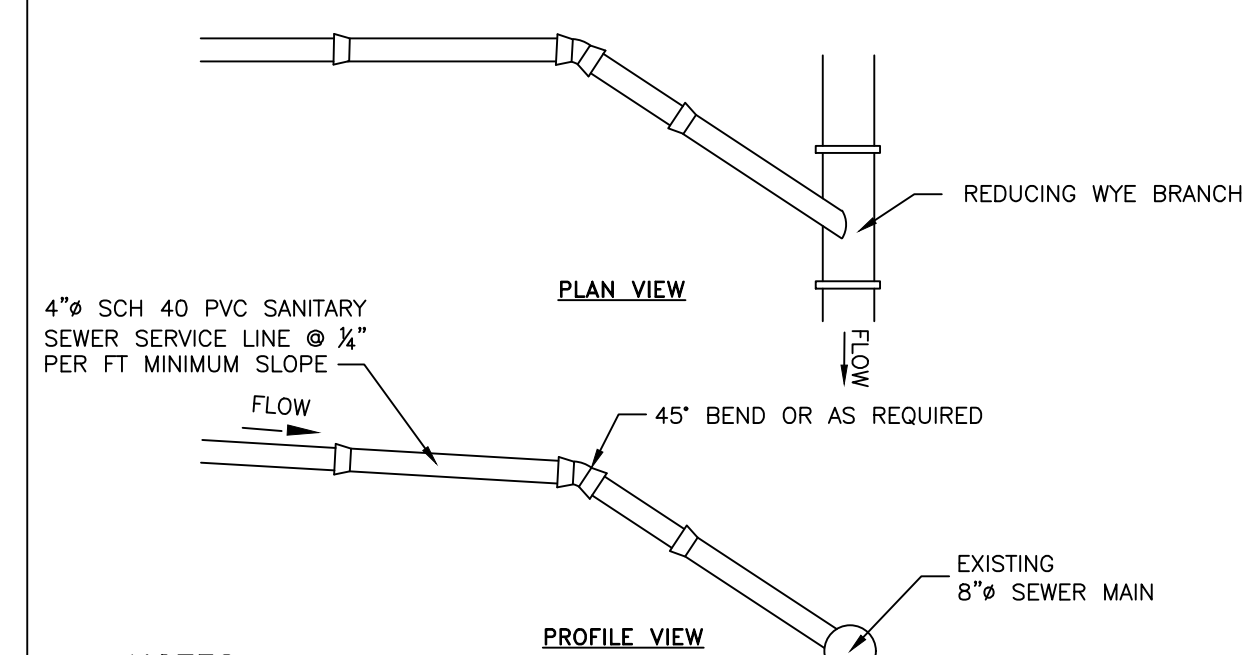

NOTES:
 1. EXCAVATION AND TRENCHING SHALL MEET ALL OSHA REQUIREMENTS.
 2. SUITABLE RUN OF TRENCH SHALL NOT INCLUDE FROZEN MATERIALS, DEBRIS, ORGANIC MATERIALS, LARGE STONES OR OTHER UNSUITABLE MATERIALS. IF THE RUN OF TRENCH MATERIAL IS FOUND TO BE UNSUITABLE, A SUITABLE BACKFILL MATERIAL SHALL BE IMPORTED AND USED.
 3. TAPPING SADDLE FOR CONNECTION OF THE PROPOSED SERVICE LINE TO THE EXISTING SEWER MAIN TO BE A 4" PRECOO HUB TAP SADDLE - MODEL #HTS4/E.

SANITARY SEWER SERVICE CONNECTION DETAIL
NOT TO SCALE

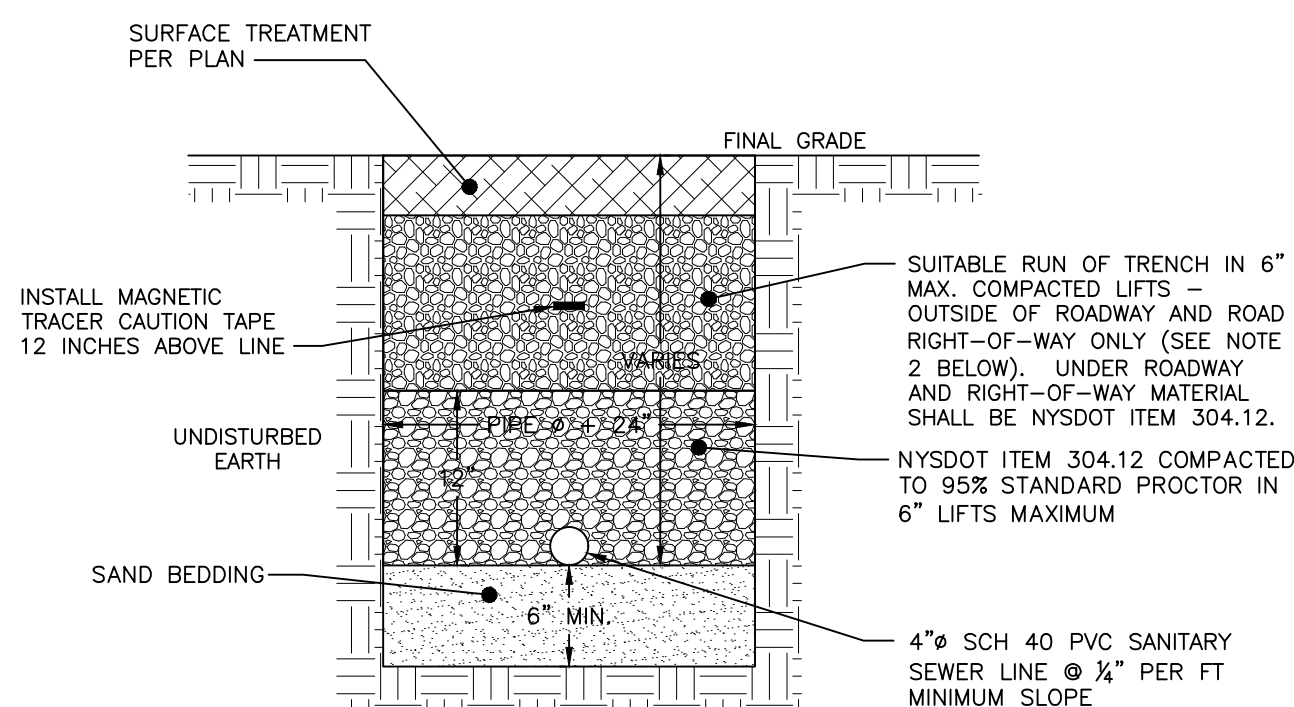

NOTES:
 1. EXCAVATION AND TRENCHING SHALL MEET ALL OSHA REQUIREMENTS.
 2. SUITABLE RUN OF TRENCH SHALL NOT INCLUDE FROZEN MATERIALS, DEBRIS, ORGANIC MATERIALS, LARGE STONES OR OTHER UNSUITABLE MATERIALS. IF THE RUN OF TRENCH MATERIAL IS FOUND TO BE UNSUITABLE, A SUITABLE BACKFILL MATERIAL SHALL BE IMPORTED AND USED.

SANITARY SEWER SERVICE TRENCH DETAIL
NOT TO SCALE

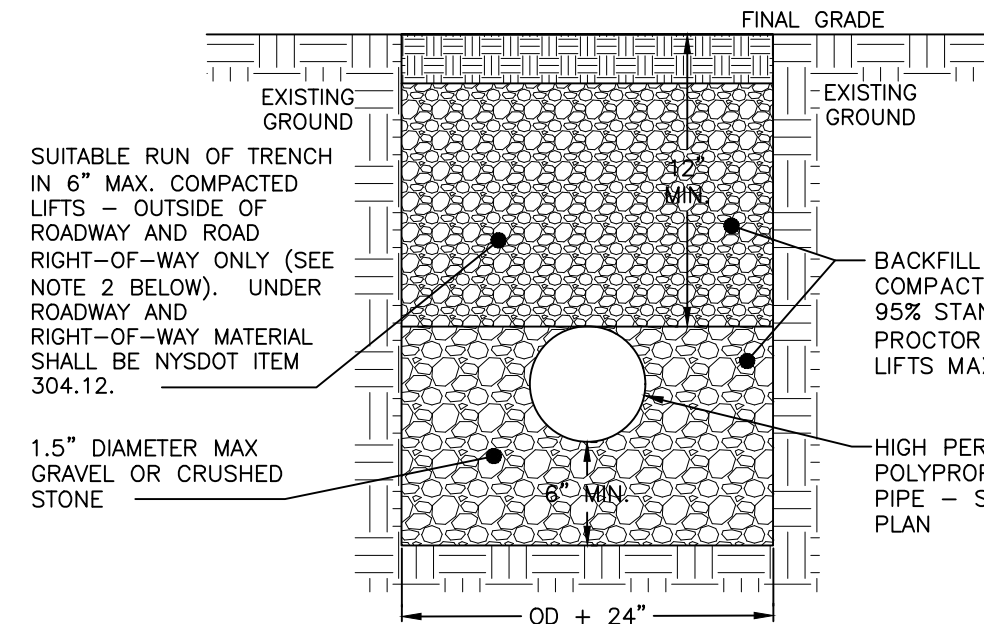

NOTES:
 1. EXCAVATION AND TRENCHING SHALL MEET ALL OSHA REQUIREMENTS.

STORM LINE TRENCH DETAIL
NOT TO SCALE

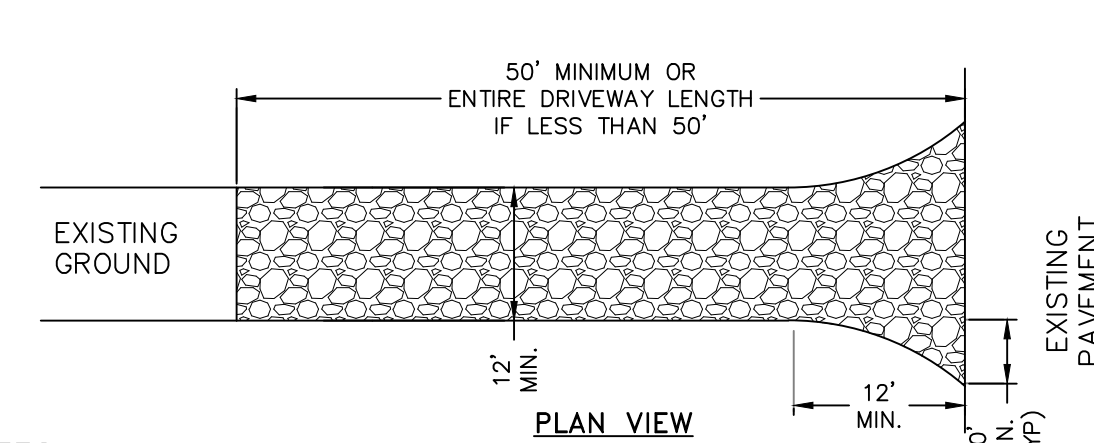

NOTES:
 1. STONE SIZE - USE 1-4 INCH STONE, OR RECLAIMED OR RECYCLED CONCRETE EQUIVALENT.
 2. THICKNESS - NOT LESS THAN SIX (6) INCHES.
 3. WIDTH - 12 FOOT MINIMUM, BUT NOT LESS THAN THE FULL WIDTH AT POINTS WHERE INGRESS OR EGRESS OCCURS. 24 FOOT MINIMUM IF SINGLE ENTRANCE TO SITE.
 4. GEOTEXTILE - WILL BE PLACED OVER THE ENTIRE AREA PRIOR TO PLACING OF STONE.
 5. SURFACE WATER - ALL SURFACE WATER FLOWING OR DIVERTED TOWARD CONSTRUCTION ENTRANCES SHALL BE PIPED BENEATH THE ENTRANCE. IF PIPING IS IMPRACTICAL, A MOUNTABLE BERM WITH 5:1 SLOPES WILL BE PERMITTED.
 6. MAINTENANCE - THE ENTRANCE SHALL BE MAINTAINED IN A CONDITION WHICH WILL PREVENT TRACKING OR FLOWING OF SEDIMENT ONTO PUBLIC RIGHTS-OF-WAY. THIS MAY REQUIRE PERIODIC TOP DRESSING WITH ADDITIONAL STONE AS CONDITIONS DEMAND AND REPAIR AND/OR CLEANOUT OF ANY MEASURE USED TO TRAP SEDIMENT. ALL SEDIMENT SPILLED, DROPPED, WASHED OR TRACTED ONTO PUBLIC RIGHTS-OF-WAY MUST BE REMOVED IMMEDIATELY.
 7. WHEN WASHING IS REQUIRED, IT SHALL BE DONE ON AN AREA STABILIZED WITH STONE AND WHICH DRAINS INTO AN APPROVED SEDIMENT TRAPPING DEVICE.
 8. PERIODIC INSPECTION AND NEEDED MAINTENANCE SHALL BE PROVIDED AFTER EACH RAIN.

STABILIZED CONSTRUCTION ENTRANCE DETAIL
NOT TO SCALE

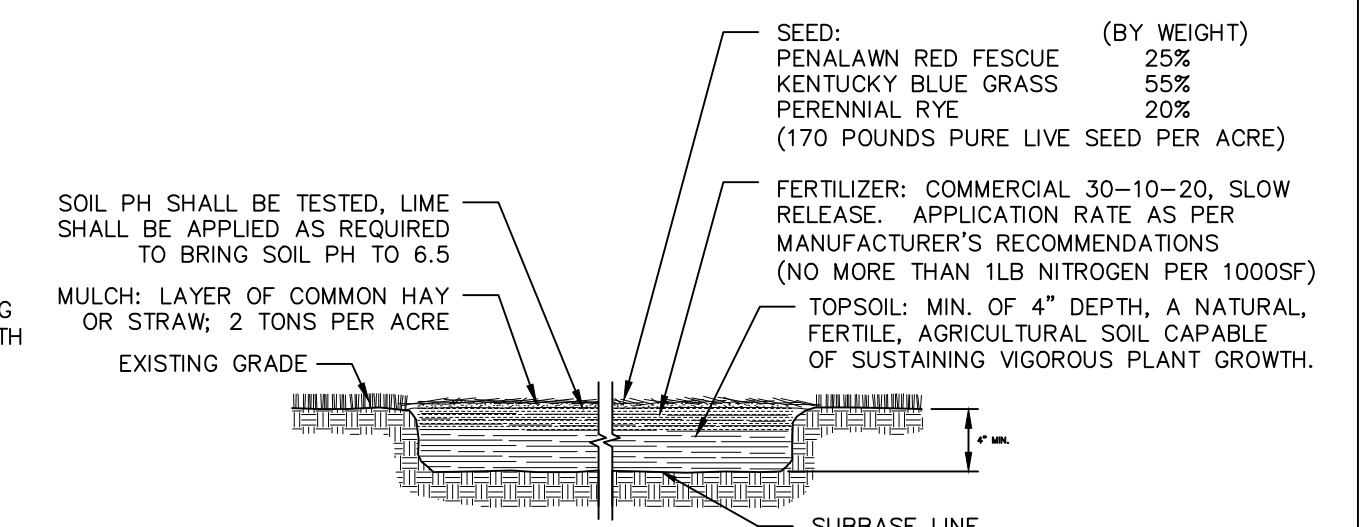

TOPSOIL SEED, FERTILIZER AND MULCH DETAIL
NOT TO SCALE

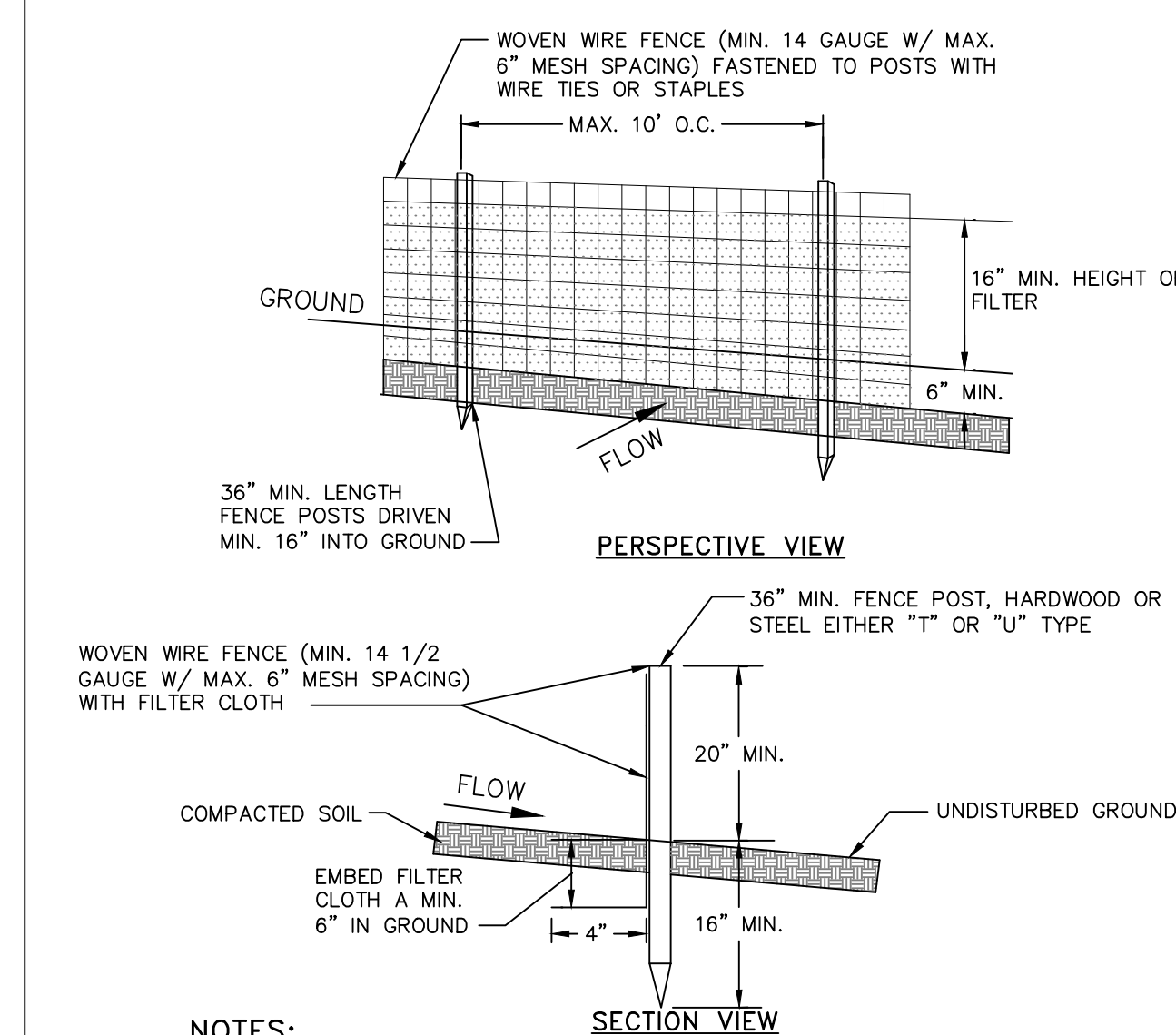

NOTES:
 1. FILTER CLOTH TO BE FASTENED SECURELY TO WOVEN WIRE FENCE WITH TIES SPACED EVERY 24" AT TOP AND MID SECTION.
 2. WHEN TWO SECTIONS OF FILTER CLOTH ADJOIN EACH OTHER THEY SHALL BE OVER-LAPPED BY SIX INCHES AND FOLDED. FILTER CLOTH SHALL BE EITHER FILTER X, MIRAFI 100X, STABILINKA T140N OR APPROVED EQUAL.
 3. PREFABRICATED UNITS SHALL BE GEOPAB, ENVIROFENCE OR APPROVED EQUAL.
 4. MAINTENANCE SHALL BE PERFORMED AS NEEDED AND MATERIAL REMOVED WHEN "BULGES" DEVELOP IN THE SILT FENCE.

SILT FENCE DETAIL
NOT TO SCALE

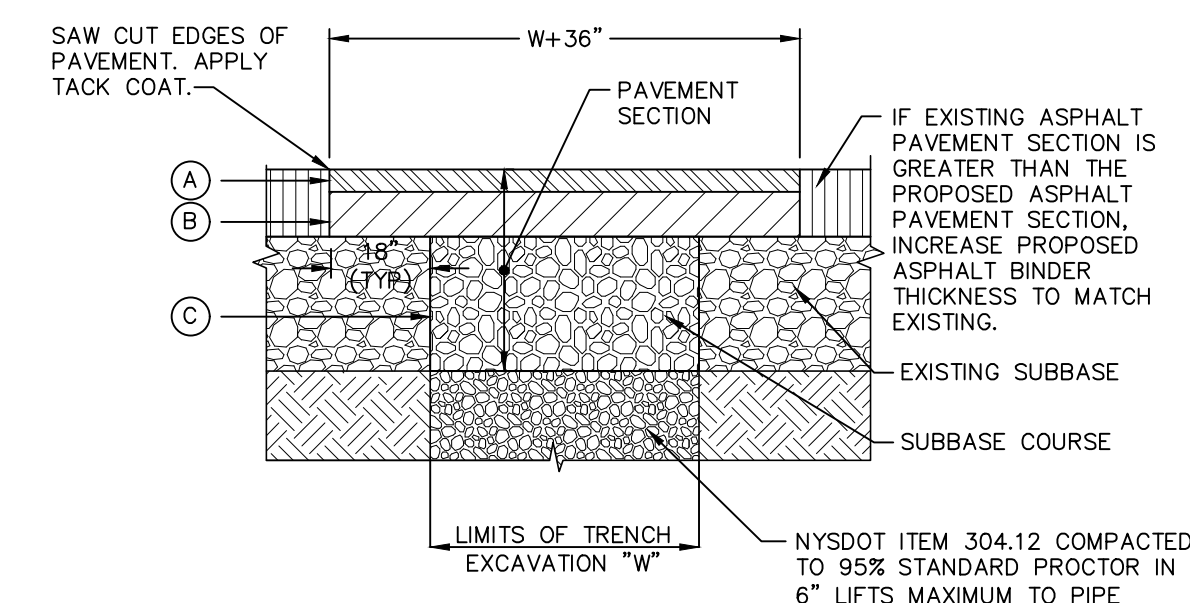

LEGEND
 (A) 1-1/2" ASPHALT CONCRETE TOP COURSE - NYS DOT TYPE 6F
 (B) 3" ASPHALT CONCRETE BINDER COURSE - NYS DOT TYPE 3
 (C) 10" GRANULAR SUBBASE COURSE - NYS DOT ITEM 304.12

NOTES:
 1. SAW CUT MIN. 18" BEYOND EXCAVATION WITH SMOOTH EDGES. 18" JOINT BETWEEN EXISTING AND NEW TOP COURSE TO BE MILLED. JOINT TO BE SEALED WITH POLYMER MODIFIED SEALER.
 2. FURNISH, PLACE, AND COMPACT SUBBASE.
 3. TACK COAT IN ACCORDANCE WITH NYS DOT STANDARD SPEC.
 4. FURNISH AND PLACE ASPHALT CONCRETE PAVEMENT AS SPECIFIED.

PAVEMENT RESTORATION DETAIL
NOT TO SCALE

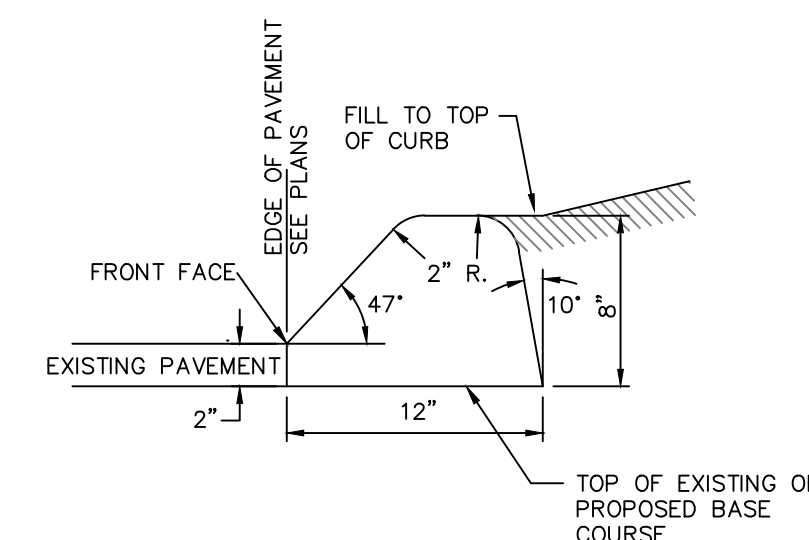

NOTE:
 DIMENSIONS SHOWN ARE STANDARD. ADJUSTMENTS TO THE ABOVE DIMENSIONS SHALL BE MADE TO MATCH EXISTING ASPHALT CURB.

ASPHALT CURB DETAIL
NOT TO SCALE

DRAWN BY: MAB		CHECKED BY: JDB		JOB NO.: 2017-004	
REVISIONS:					
NO.	DATE	DESCRIPTION	BY		
1	7/25/17	PER CONSULTANT'S COMMENTS	MAB		

APPROVED BY RESOLUTION OF THE PLANNING BOARD OF THE CITY OF BEACON, NEW YORK, ON THE _____ DAY OF _____, 20____ SUBJECT TO ALL REQUIREMENTS AND CONDITIONS OF SAID RESOLUTION. ANY CHANGE, ERASURE, MODIFICATION OR REVISION OF THIS PLAT, AS APPROVED, SHALL VOID THIS APPROVAL.

SIGNED THIS _____ DAY OF _____, 20____ BY _____

CHAIRMAN

SECRETARY

IN ABSENCE OF THE CHAIRMAN OR SECRETARY, THE ACTING CHAIRMAN OR ACTING SECRETARY RESPECTIVELY MAY SIGN IN THIS PLACE.

CONSTRUCTION DETAILS SPACCARELLI SUBDIVISION

KNEVELS AVE & TIORONDA AVE
CITY OF BEACON
DUTCHESS COUNTY, NEW YORK
TAX ID: 5954-16-950472
SCALE: AS NOTED
MARCH 28, 2017

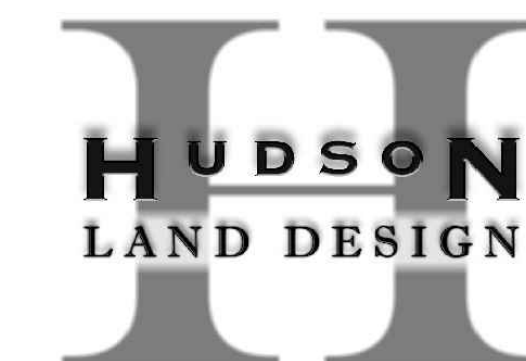

HUDSON LAND DESIGN
PROFESSIONAL ENGINEERING P.C.
174 MAIN STREET
BEACON, NEW YORK 12508
PH: 845-440-6926 F: 845-440-6637



JON D. BODENDORF, P.E.
NYS LICENSE NO. 076245
DANIEL G. KOEHLER, P.E.
NYS LICENSE NO. 082716