

FLEXIBLE JOINT REQUIREMENTS

SEWER PIPE TYPE	FLEXIBLE JOINT TYPE IN & OUT	*DISTANCE (FEET)
DUCTILE IRON	STD RUBBER GASKET PIPE JOINT ONLY	10' MAX
PVC	STD RUBBER GASKET PIPE JOINT ONLY	3' MAX

FLEXIBLE JOINT REQUIREMENTS

SEWER PIPE TYPE	FLEXIBLE JOINT TYPE IN & OUT	*DISTANCE (FEET)
DUCTILE IRON	STD RUBBER GASKET PIPE JOINT ONLY	10' MAX
PVC	STD RUBBER GASKET PIPE JOINT ONLY	3' MAX

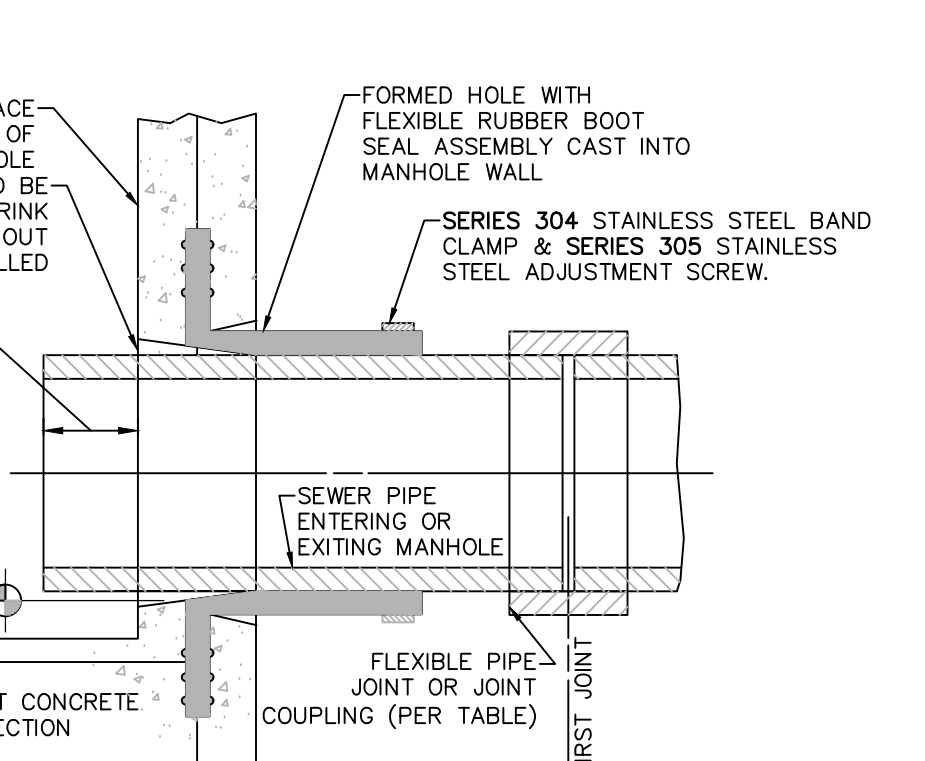
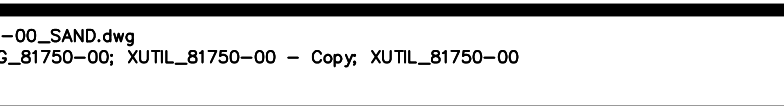
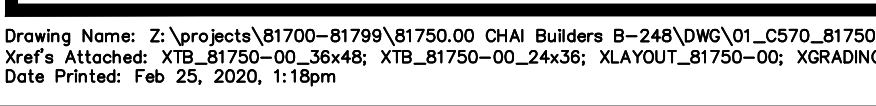
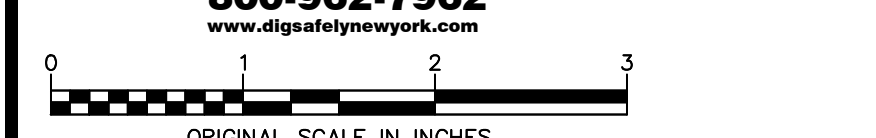
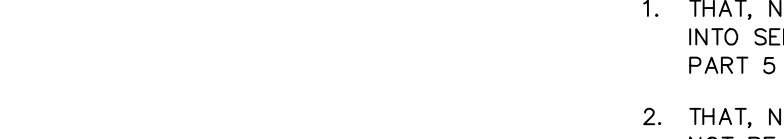
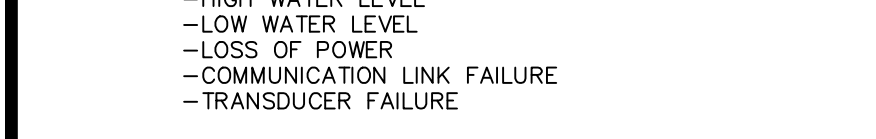
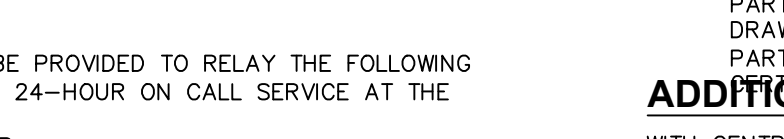
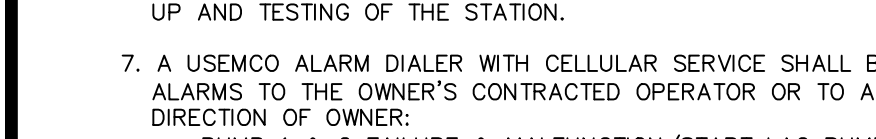
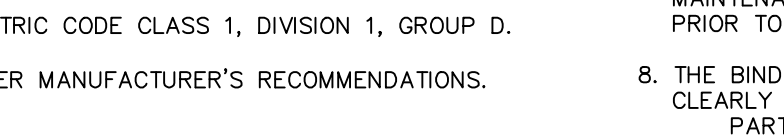
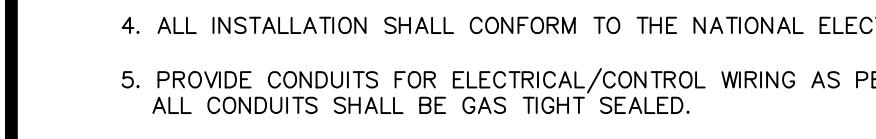
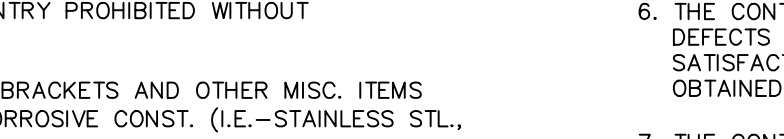
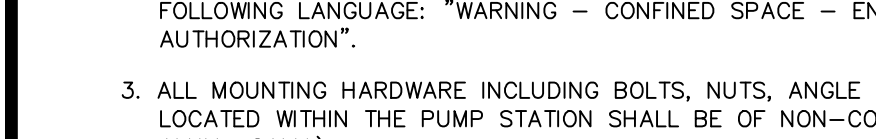
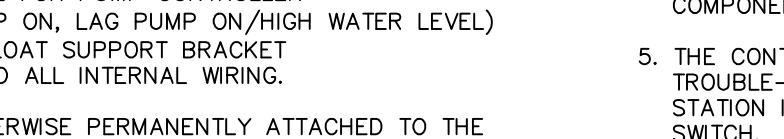
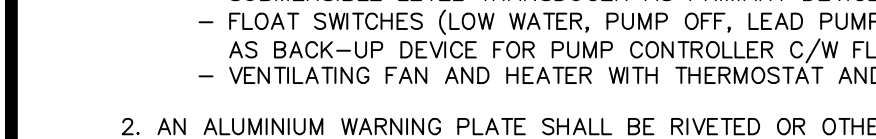
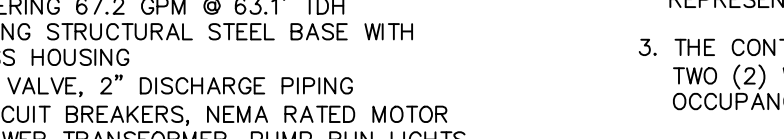
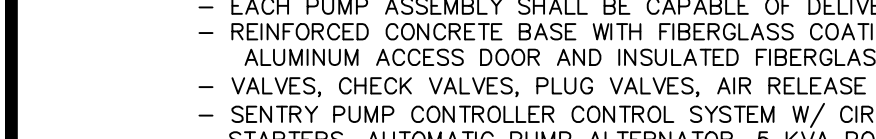
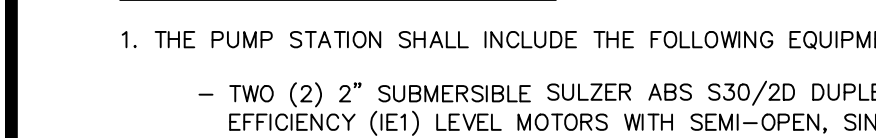
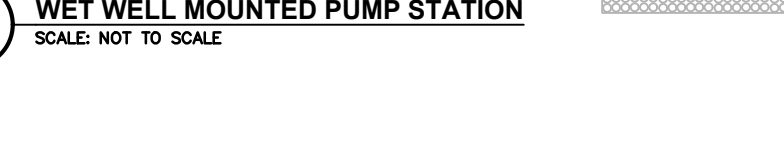
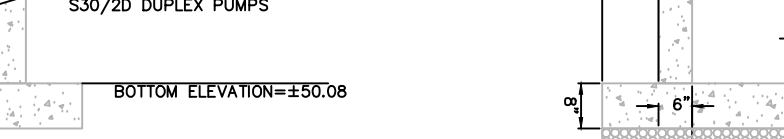
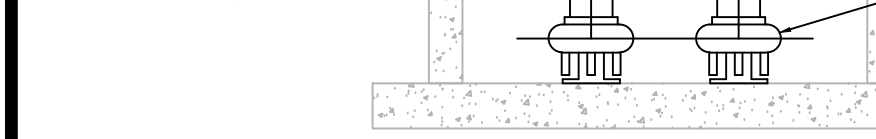
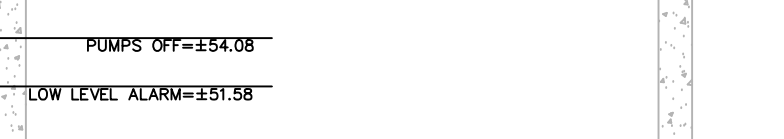
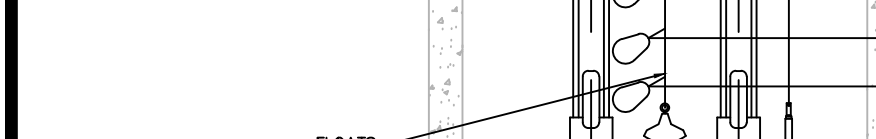
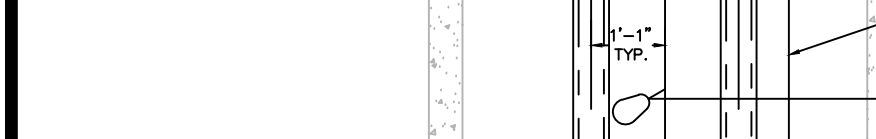
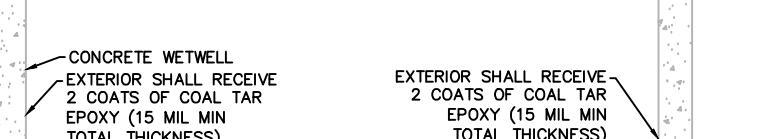
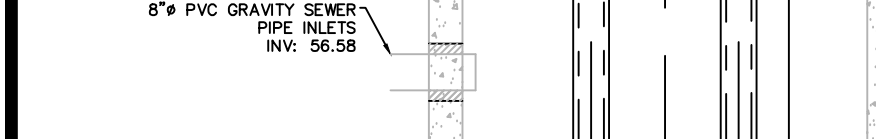
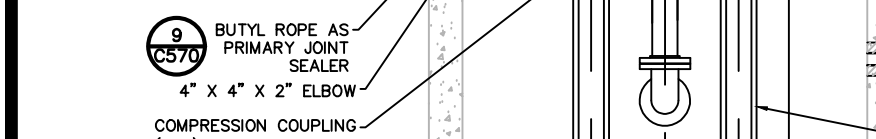
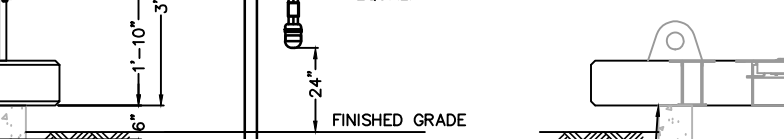
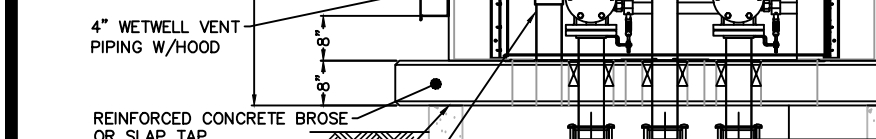
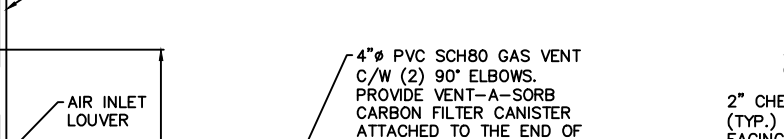
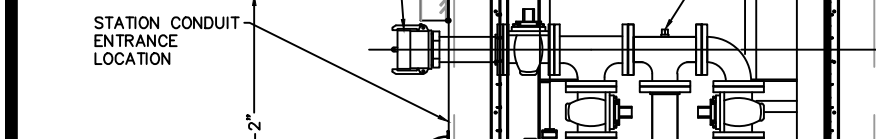
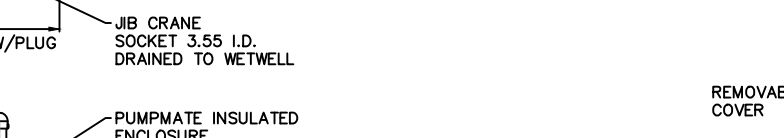
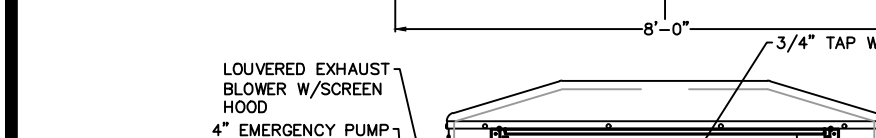
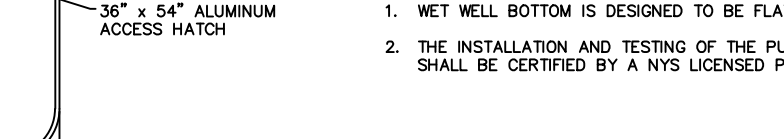
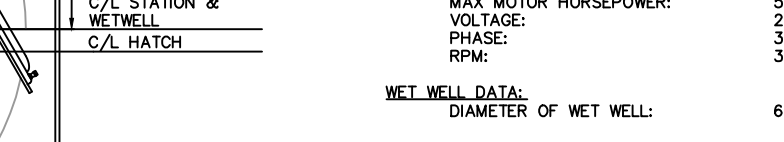
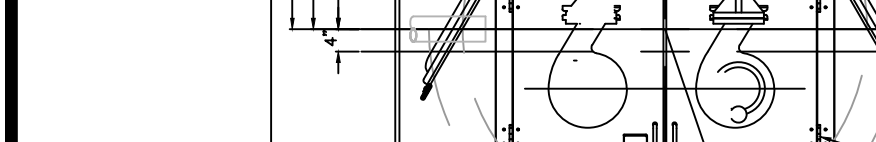
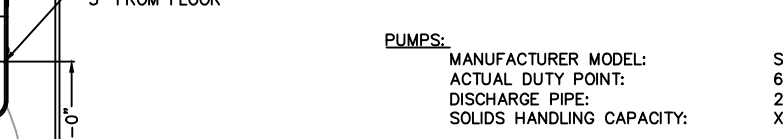
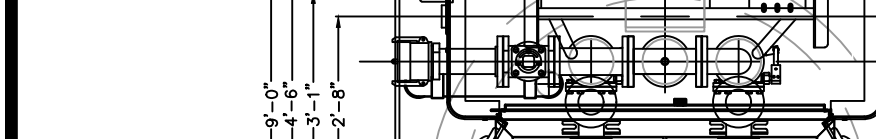
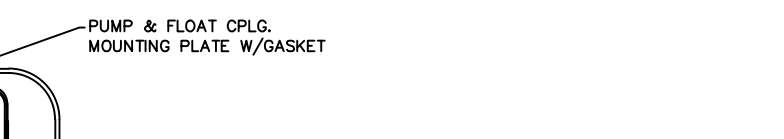
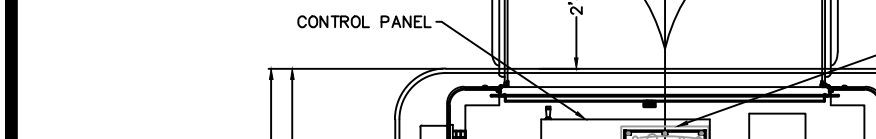
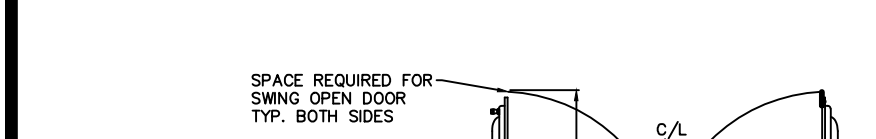
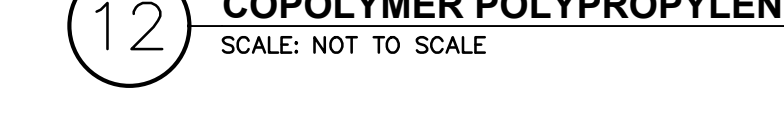
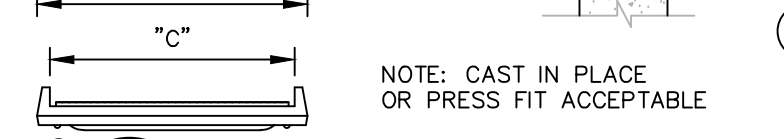
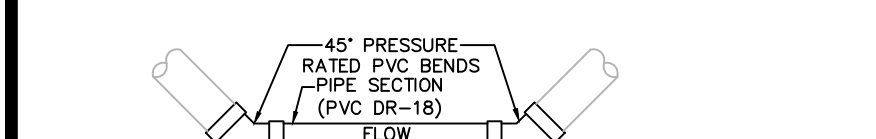
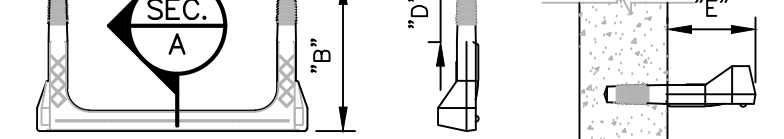
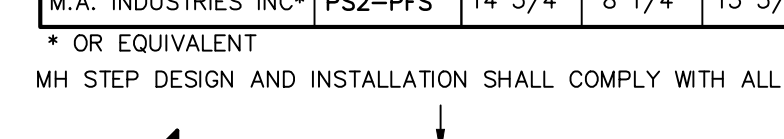
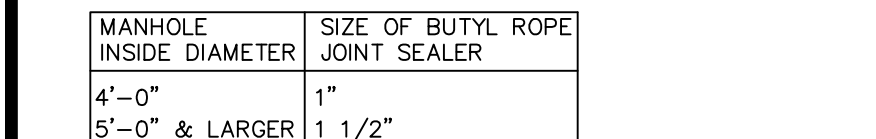
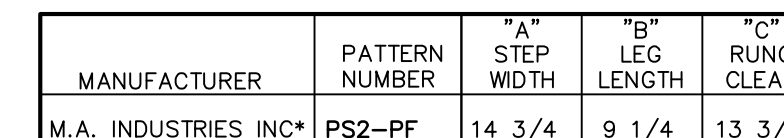
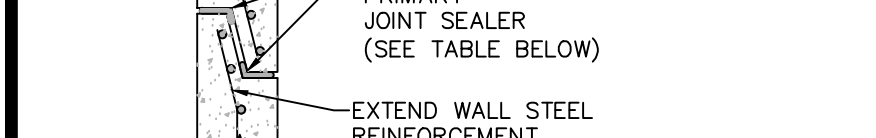
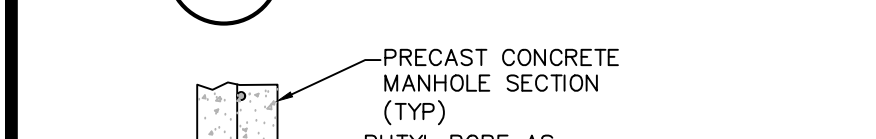
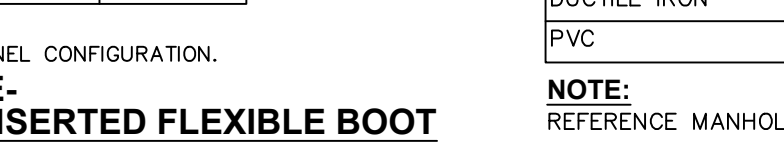

FLEXIBLE JOINT REQUIREMENTS

SEWER PIPE TYPE	FLEXIBLE JOINT TYPE IN & OUT	*DISTANCE (FEET)
DUCTILE IRON	STD RUBBER GASKET PIPE JOINT ONLY	10' MAX
PVC	STD RUBBER GASKET PIPE JOINT ONLY	3' MAX

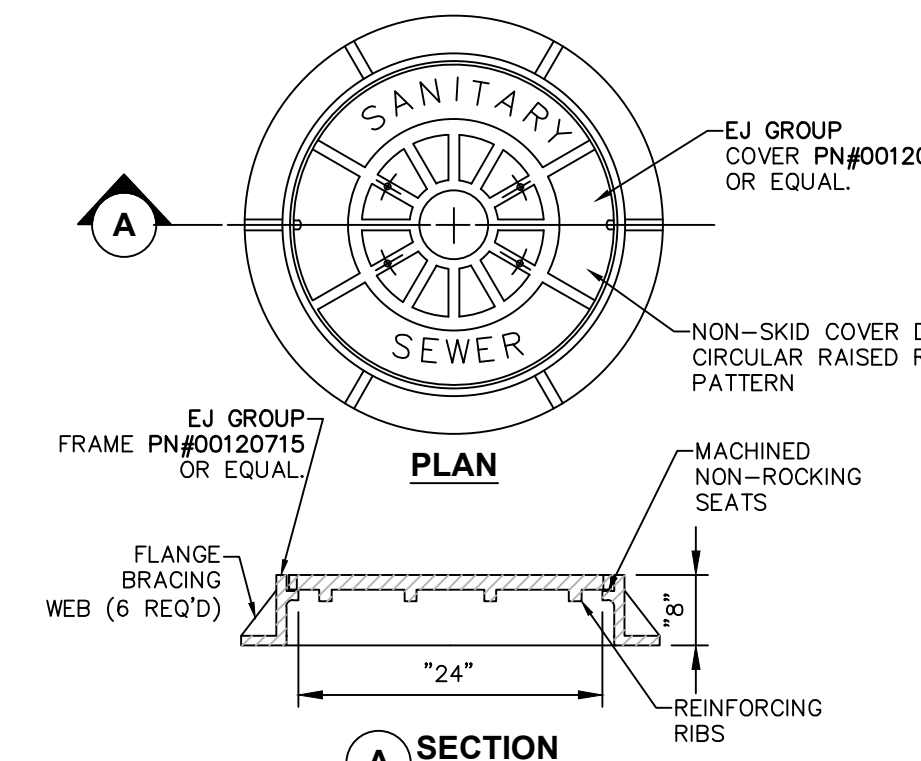
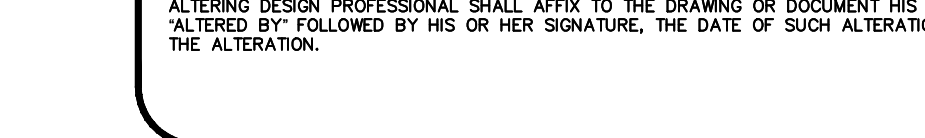
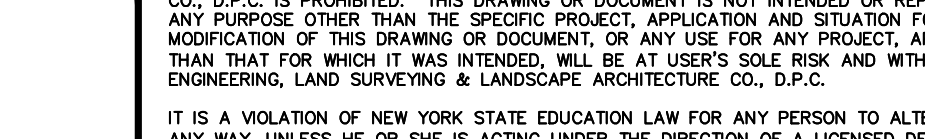
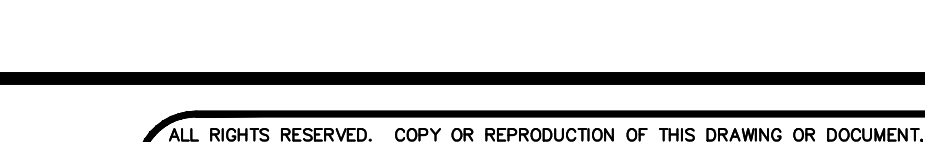
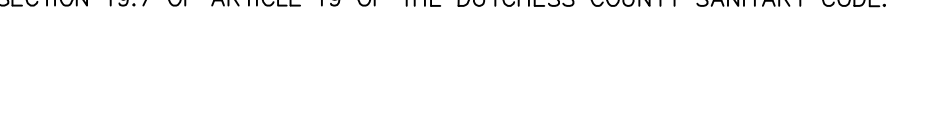
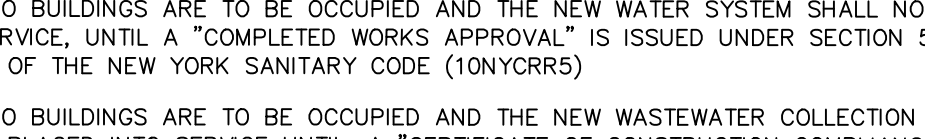
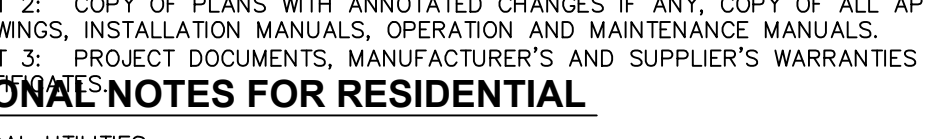
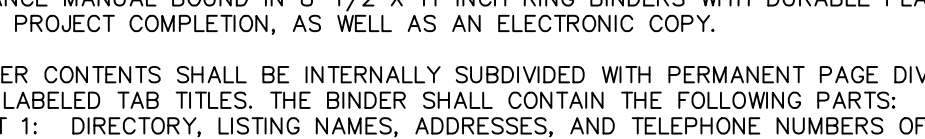
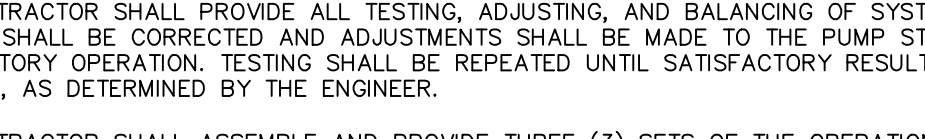
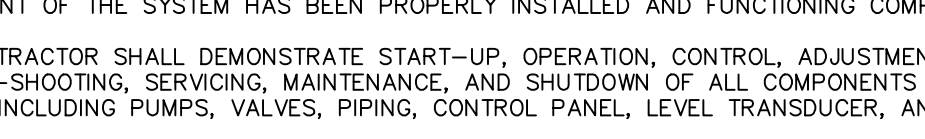
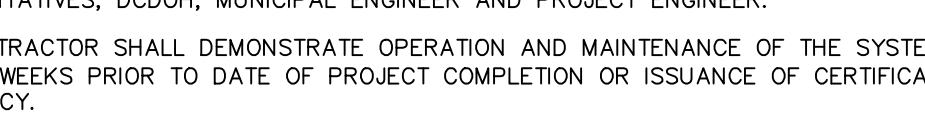
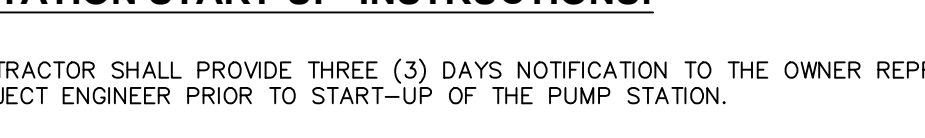
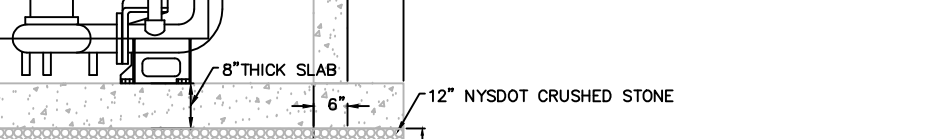
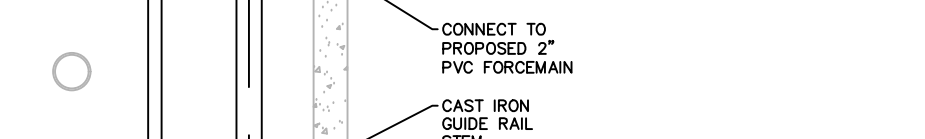
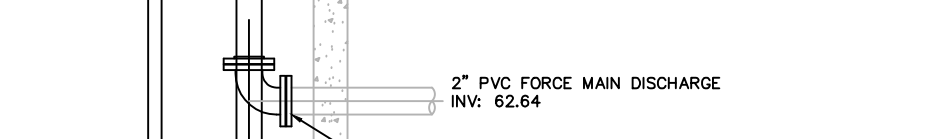
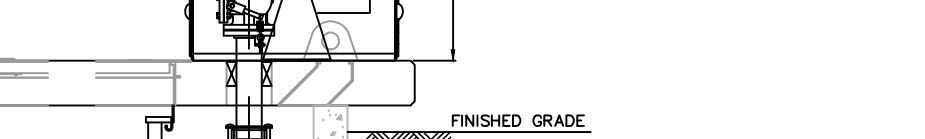
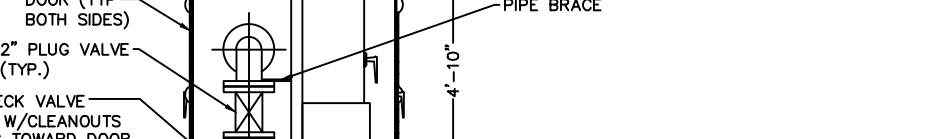
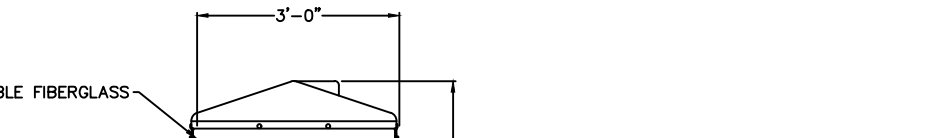
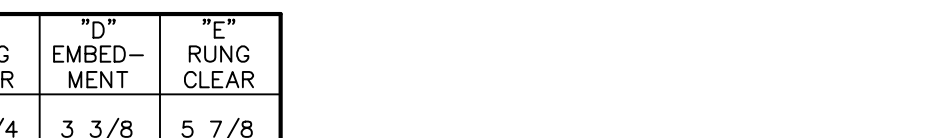
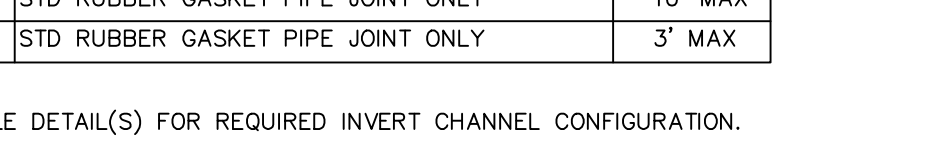

FLEXIBLE JOINT REQUIREMENTS

SEWER PIPE TYPE	FLEXIBLE JOINT TYPE IN & OUT	*DISTANCE (FEET)
DUCTILE IRON	STD RUBBER GASKET PIPE JOINT ONLY	10' MAX
PVC	STD RUBBER GASKET PIPE JOINT ONLY	3' MAX

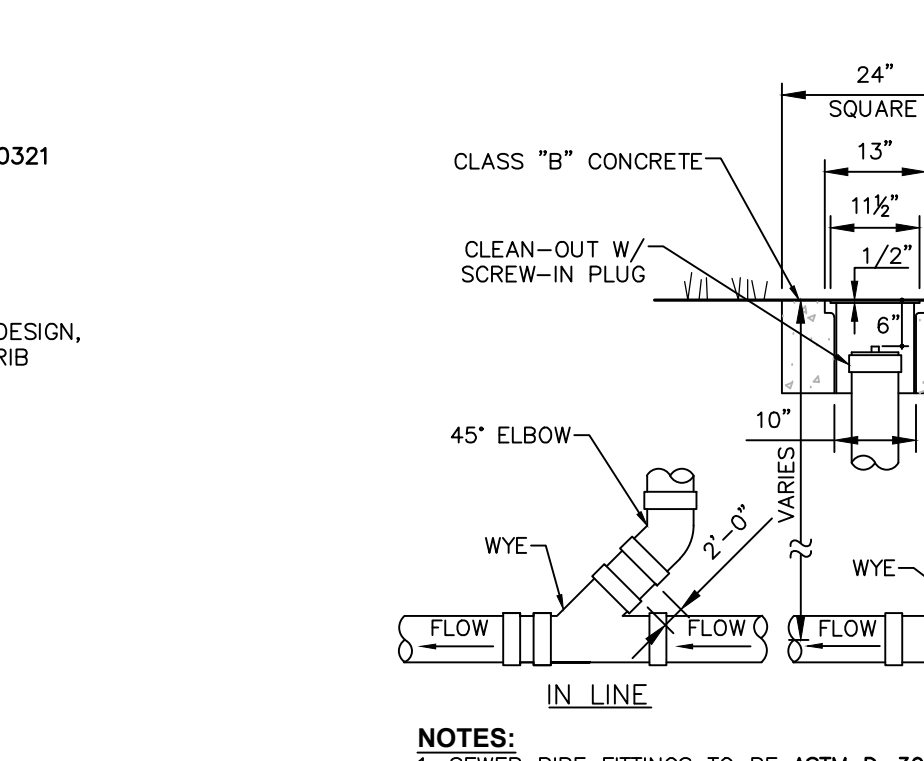
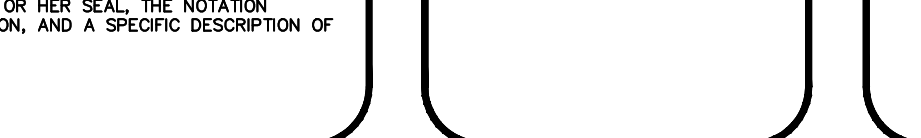
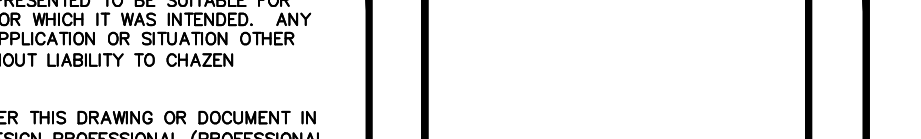
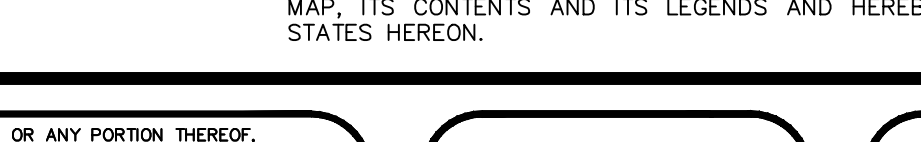
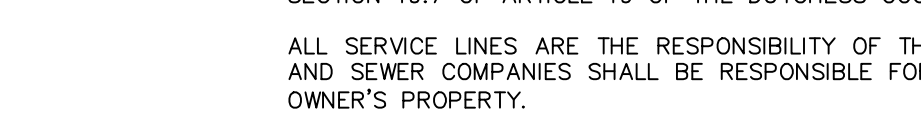
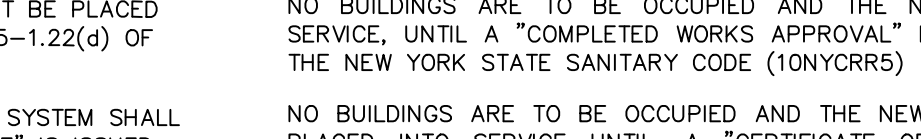
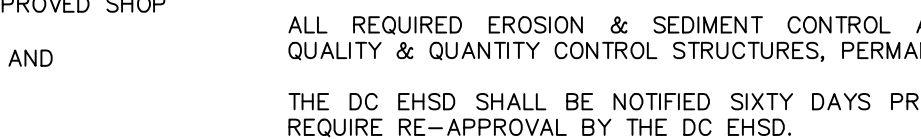
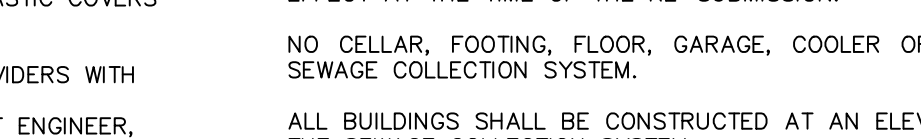
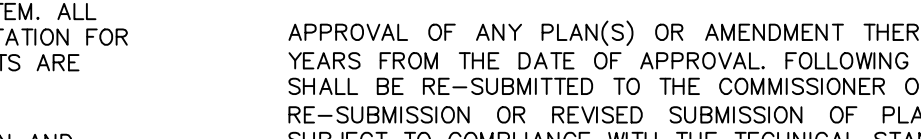
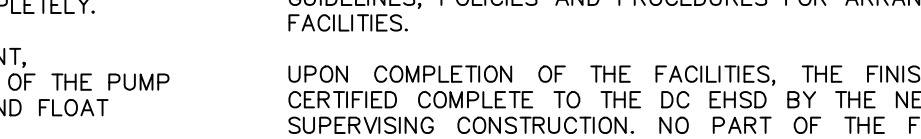
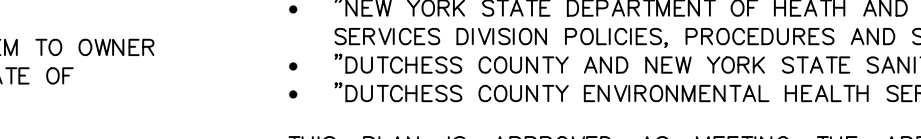
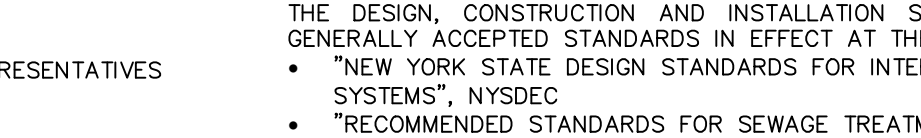
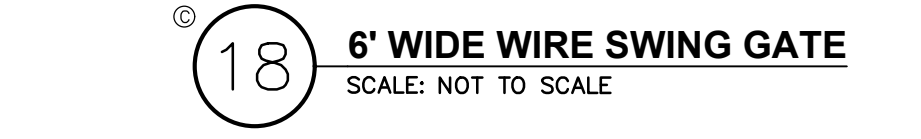
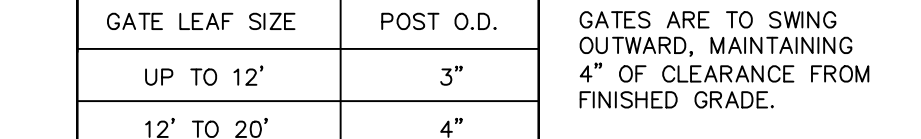
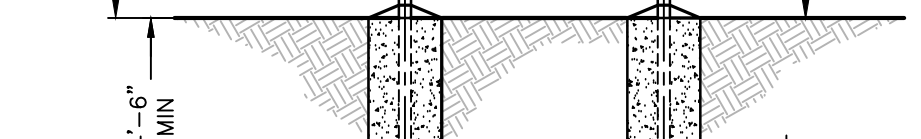
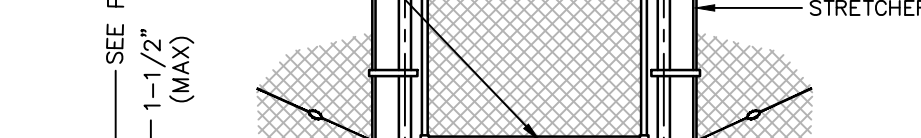
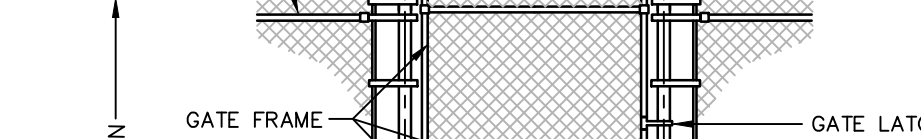
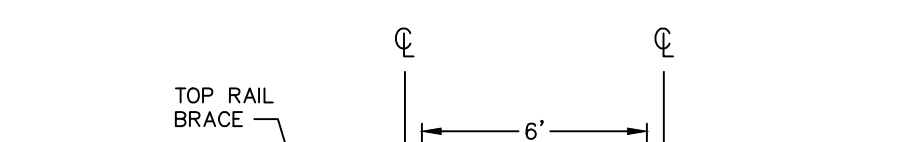
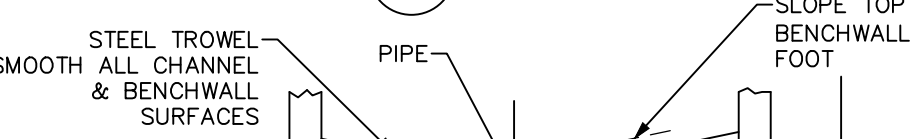
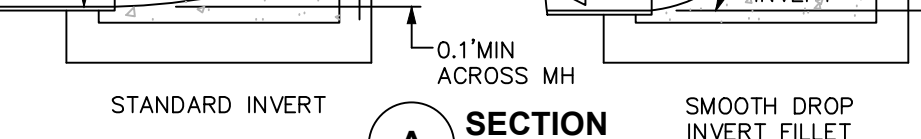
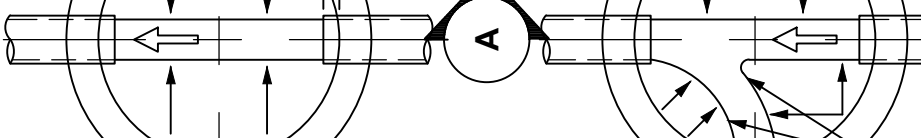
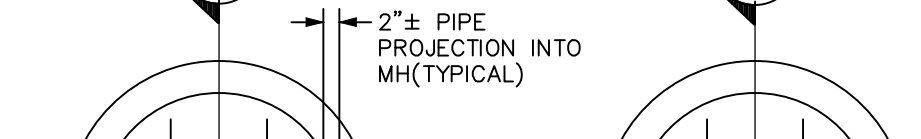

FLEXIBLE JOINT REQUIREMENTS

SEWER PIPE TYPE	FLEXIBLE JOINT TYPE IN & OUT	*DISTANCE (FEET)
DUCTILE IRON	STD RUBBER GASKET PIPE JOINT ONLY	10' MAX
PVC	STD RUBBER GASKET PIPE JOINT ONLY	3' MAX

