

NO.	DATE	REVISIONS:	BY	NO.	DATE	REVISIONS:	BY
1	12/25/18	REVISED FOR PLANNING BOARD SUBMISSION	MAB	7	12/31/19	REVISED PER PLANNING BOARD COMMENTS	CMB
2	02/28/19	REVISED PER PLANNING BOARD SUBMISSION	MAB				
3	03/29/19	REVISED PER PLANNING BOARD COMMENTS	MAB				
4	04/29/19	REVISED PER PLANNING BOARD COMMENTS	MAB				
5	05/28/19	NO CHANGE THIS SHEET	MAB				
6	10/29/19	NO CHANGE THIS SHEET	CMB				

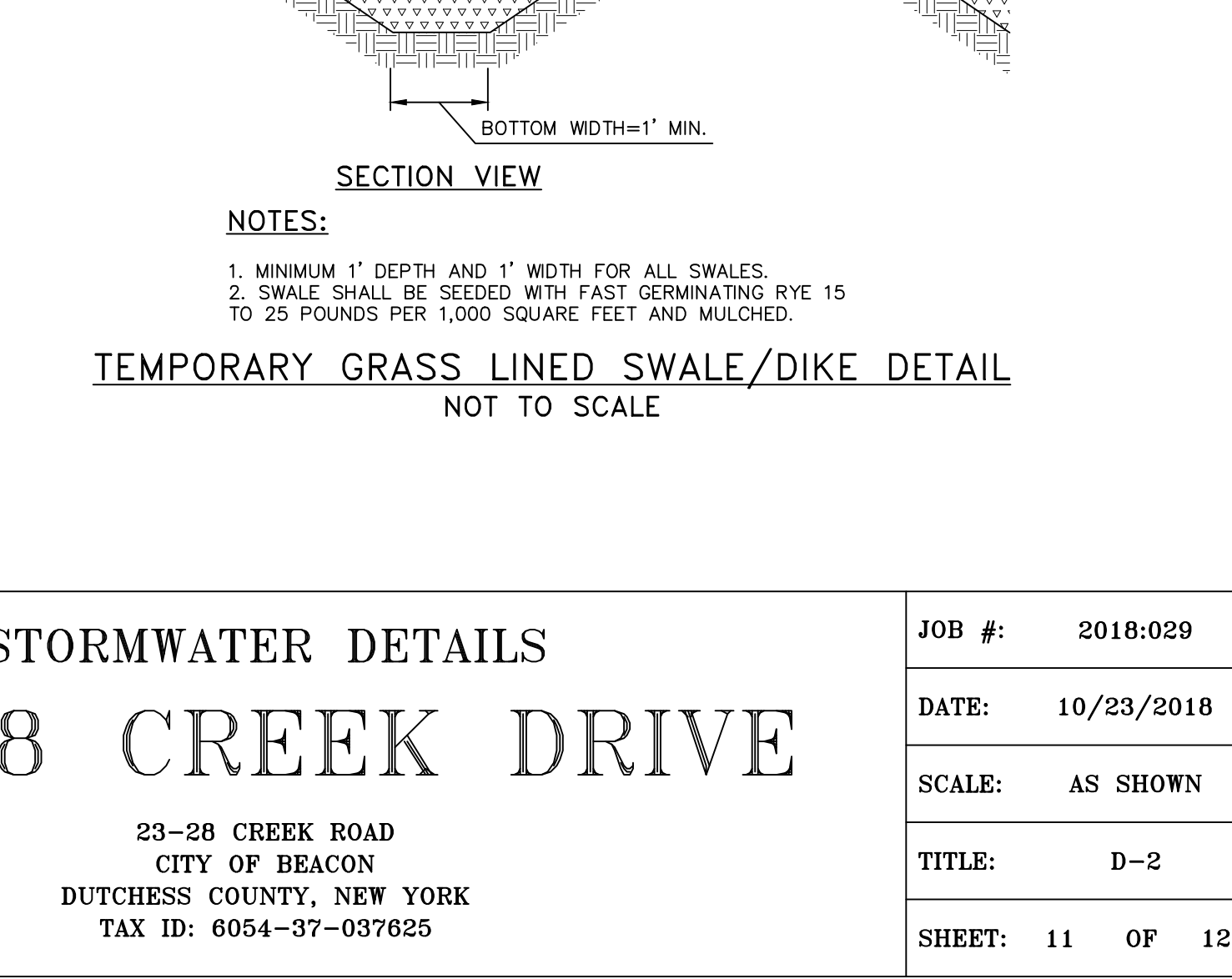
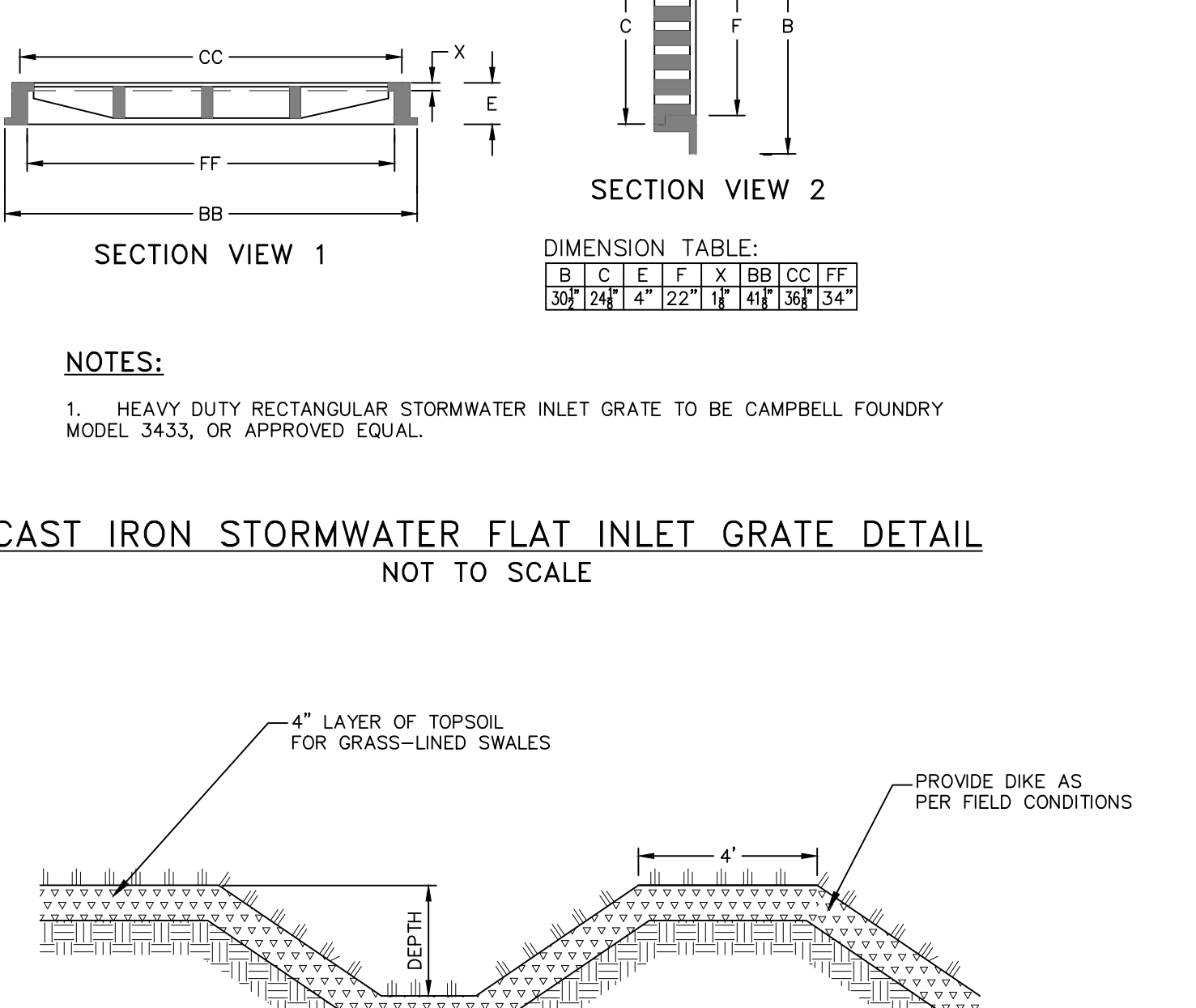
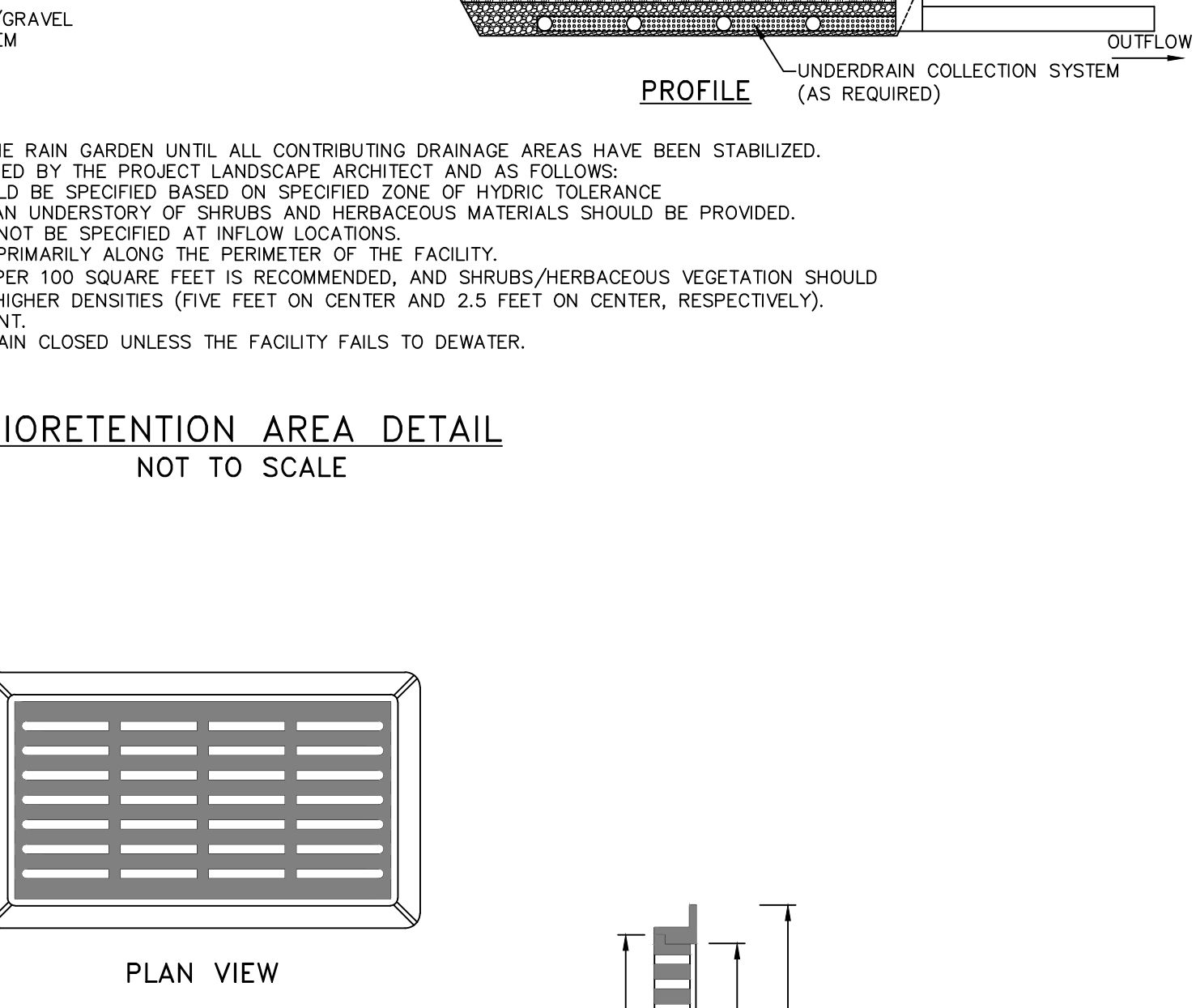
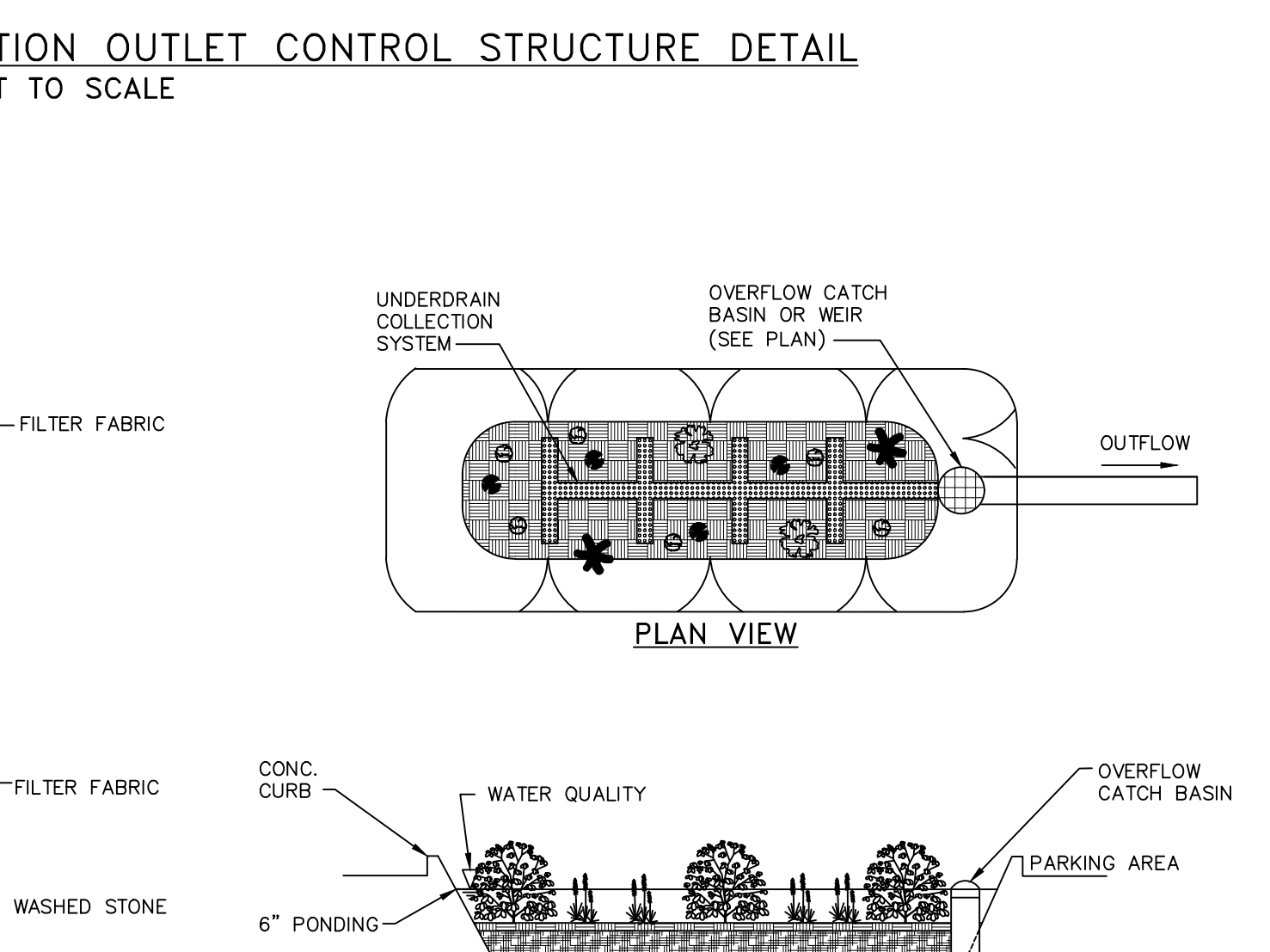
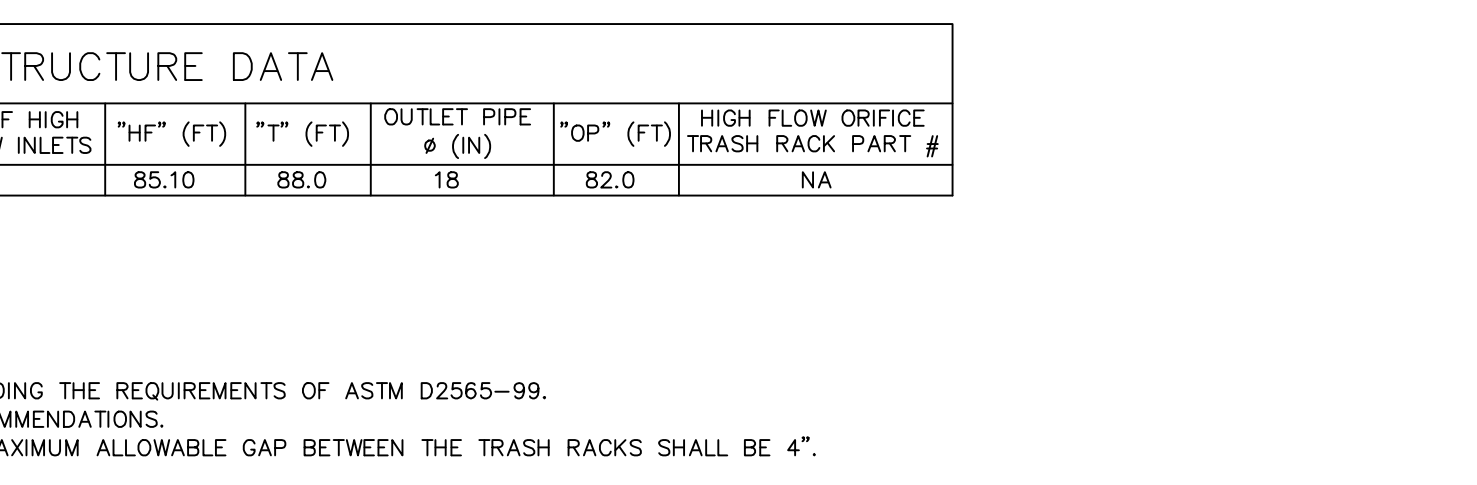
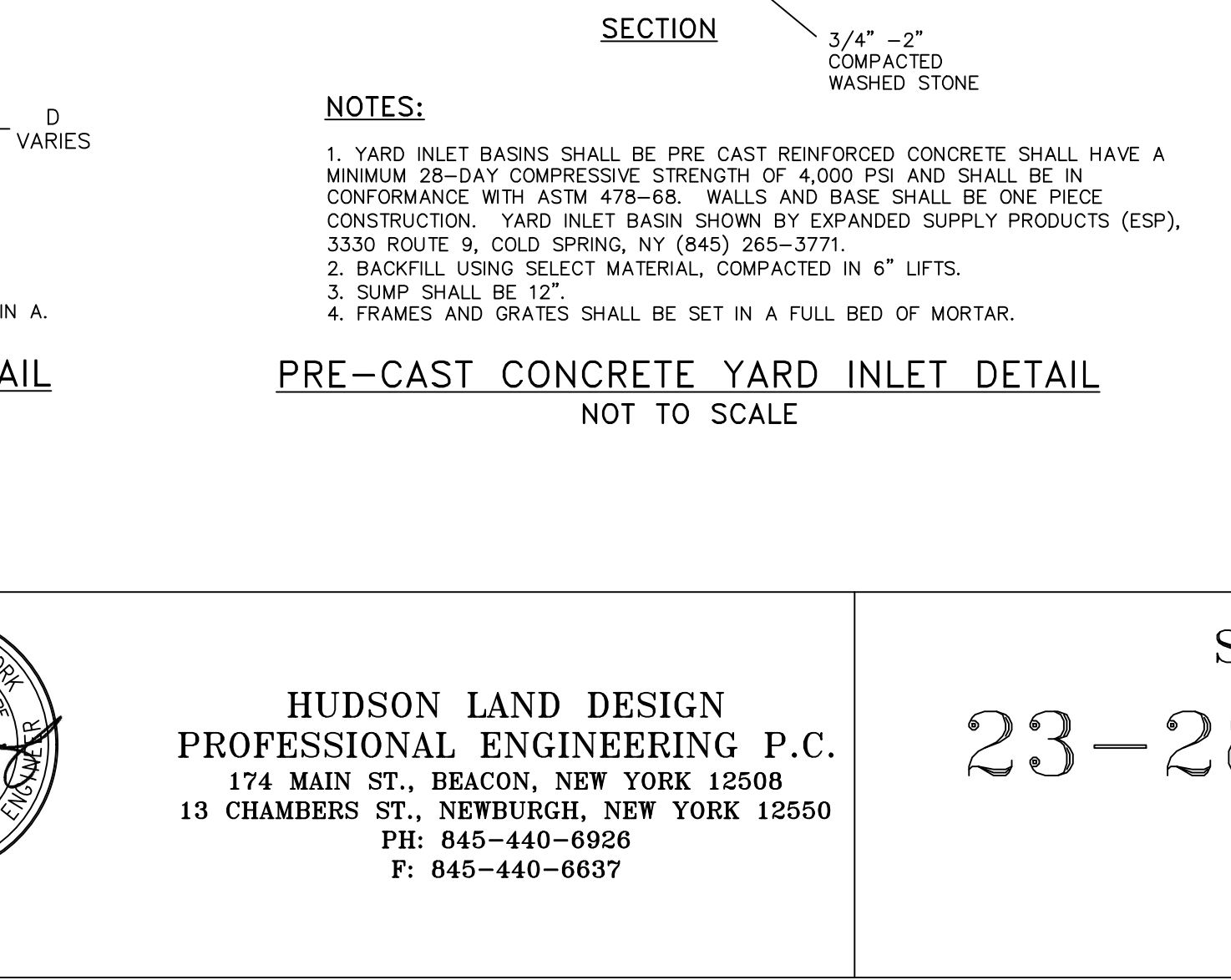
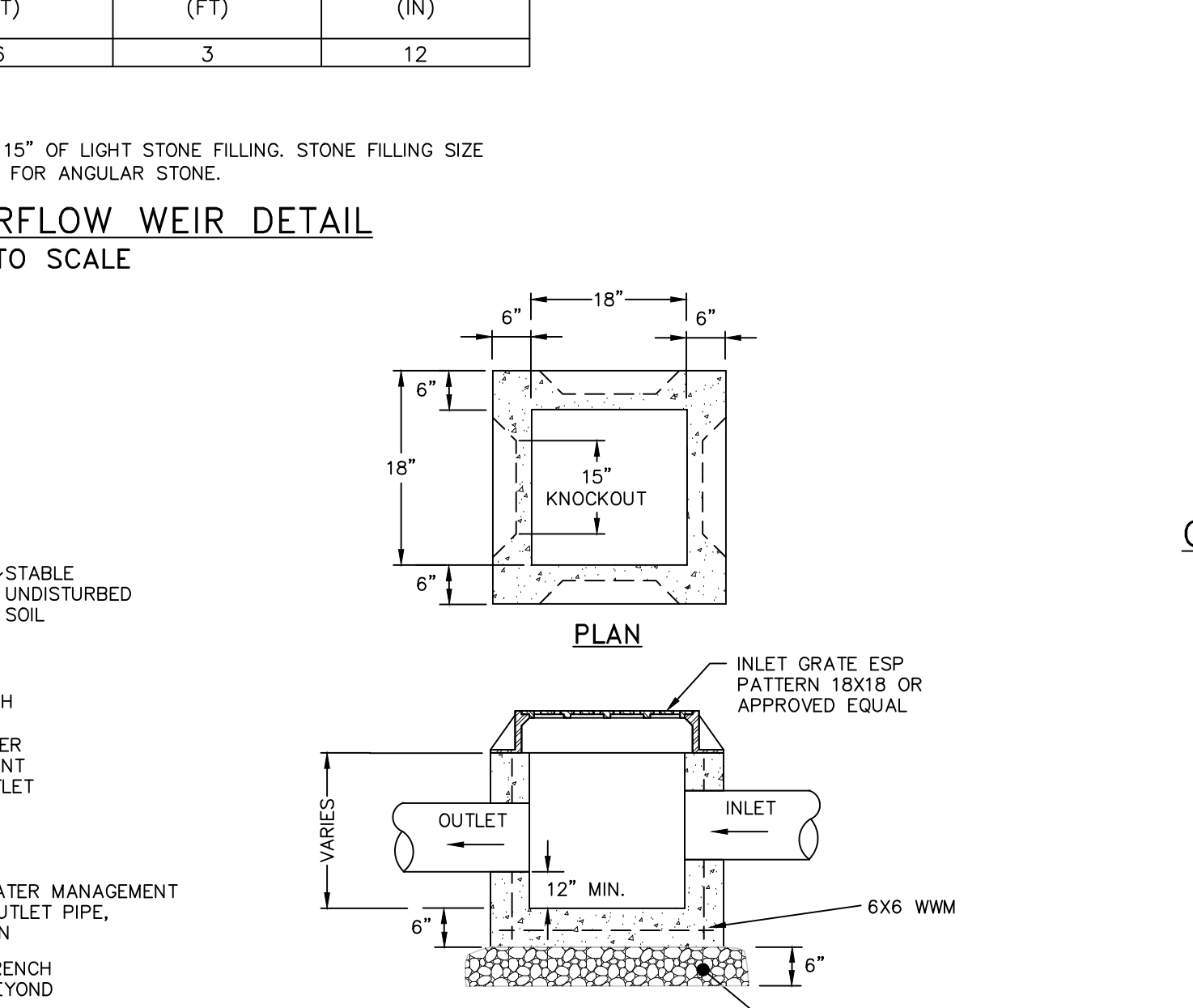
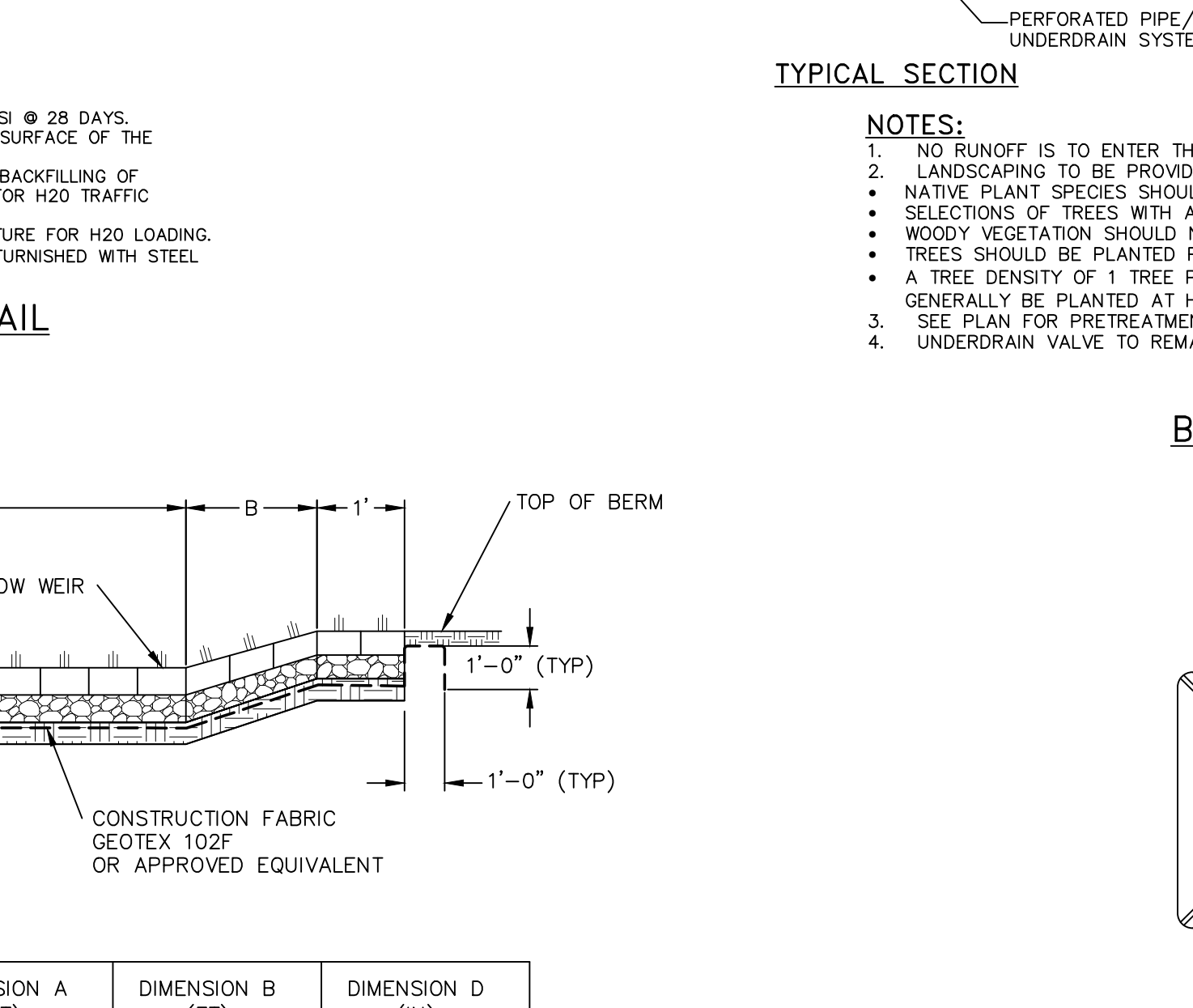
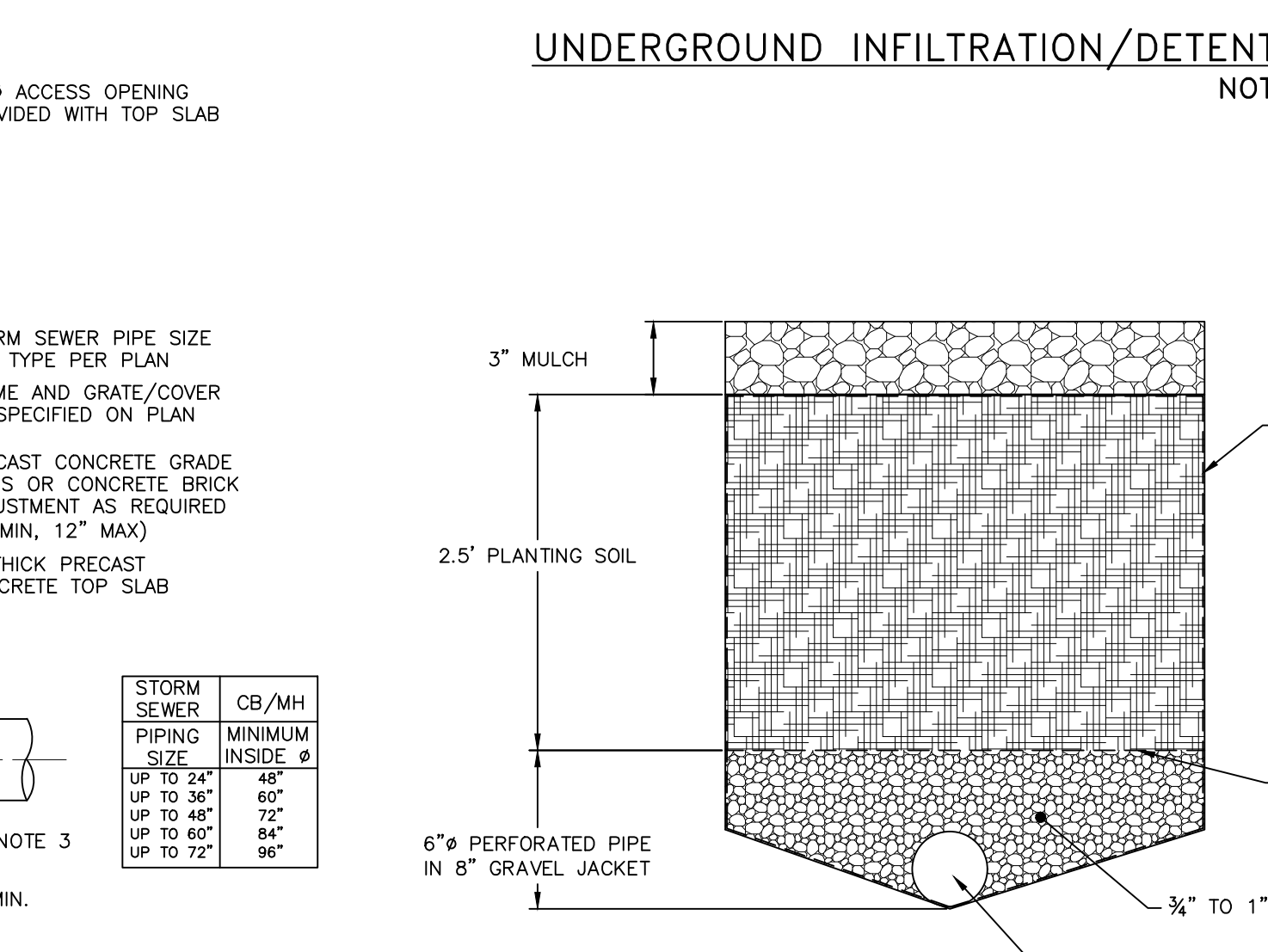
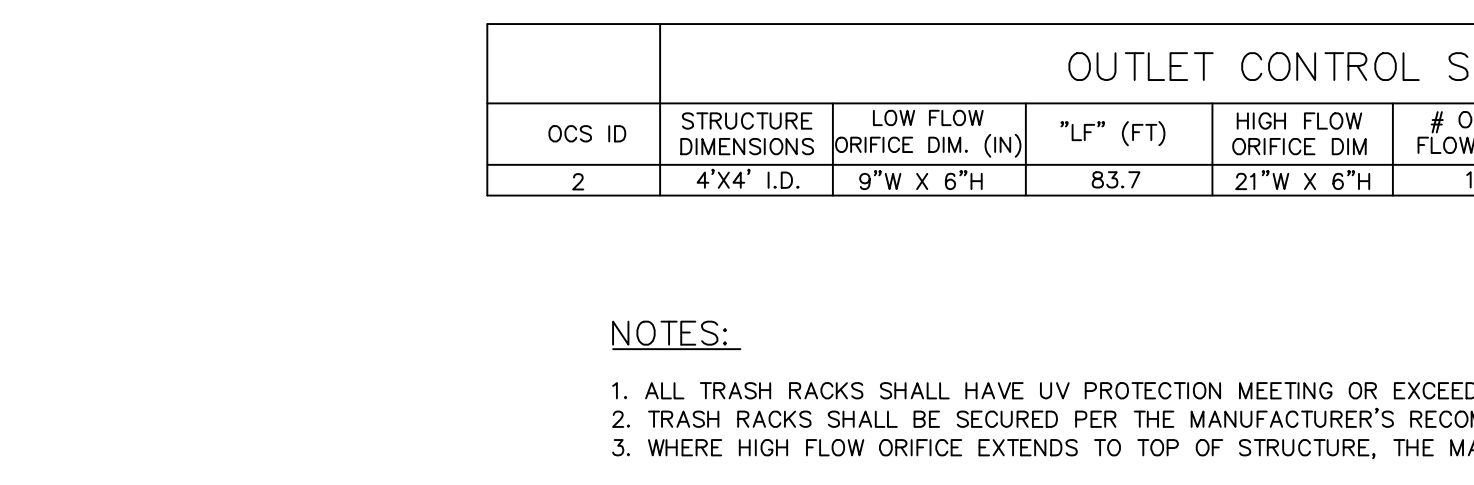
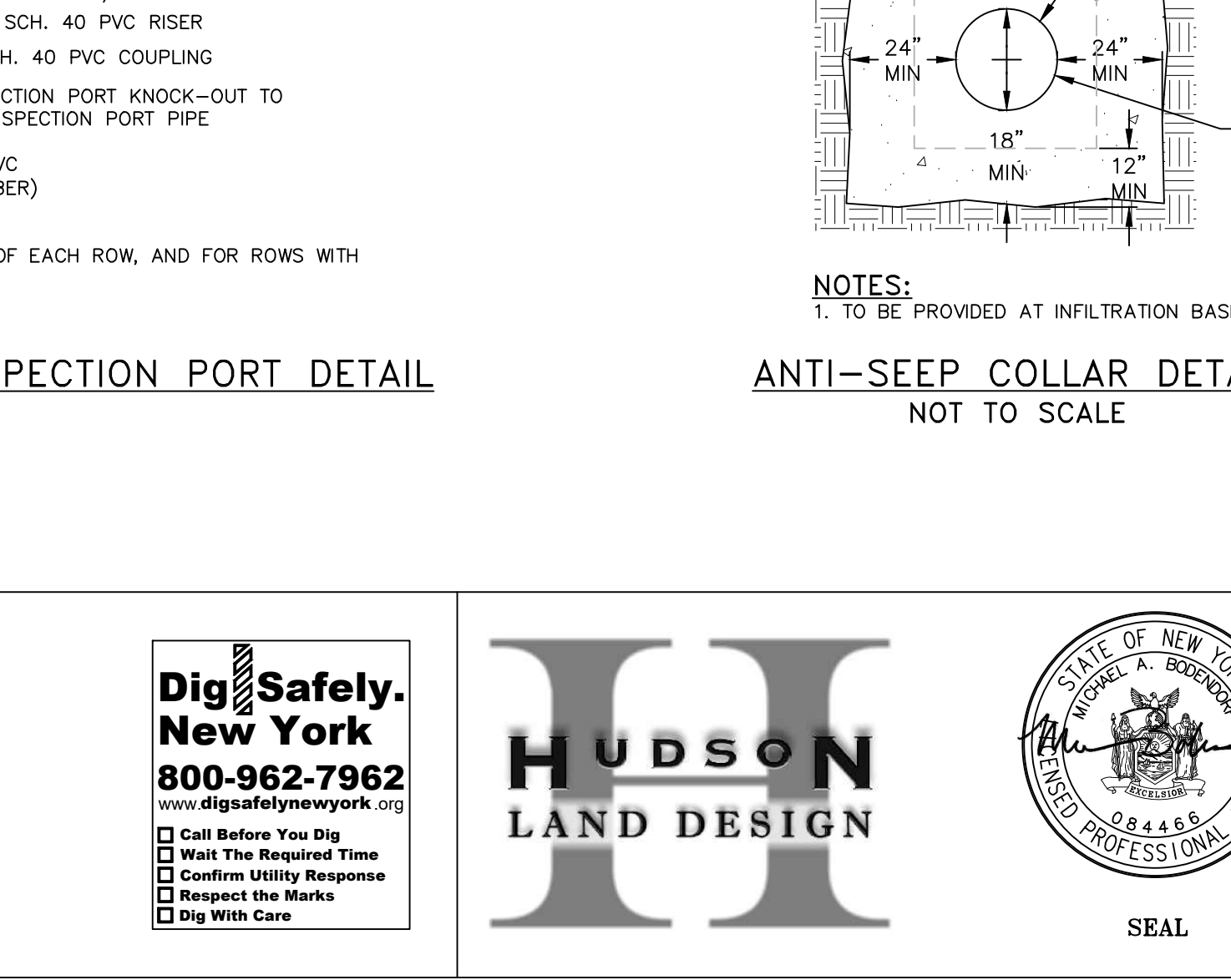
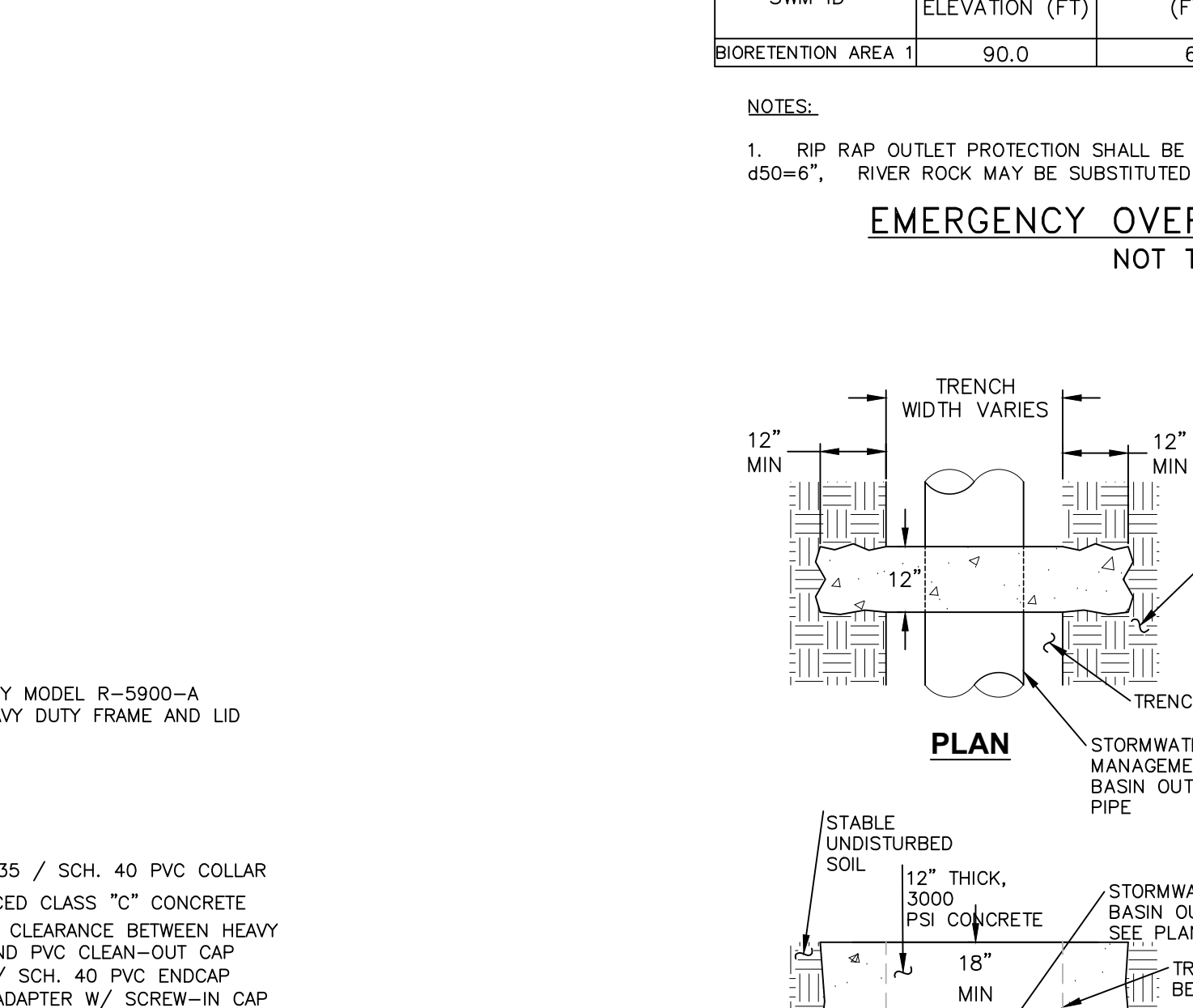
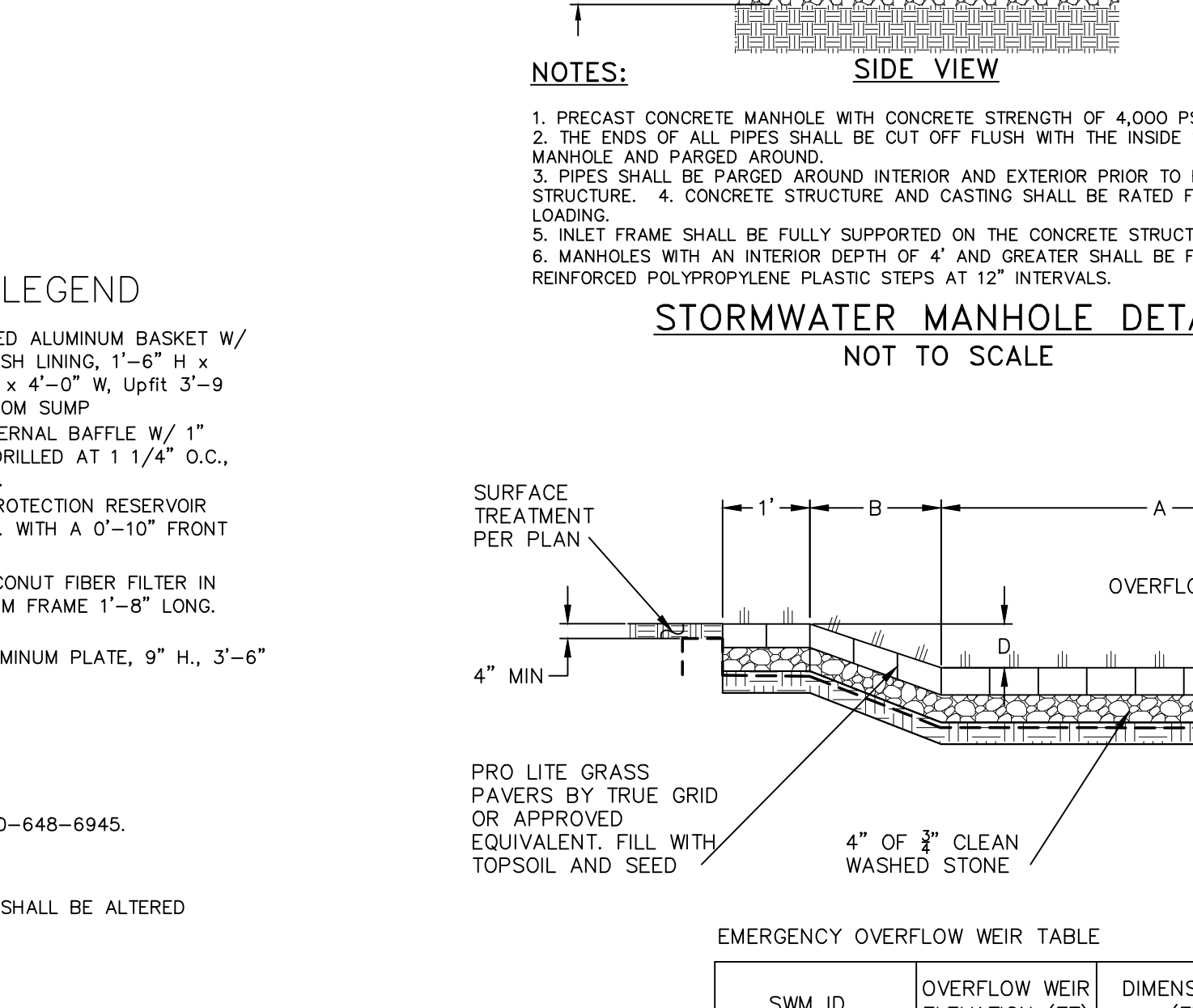
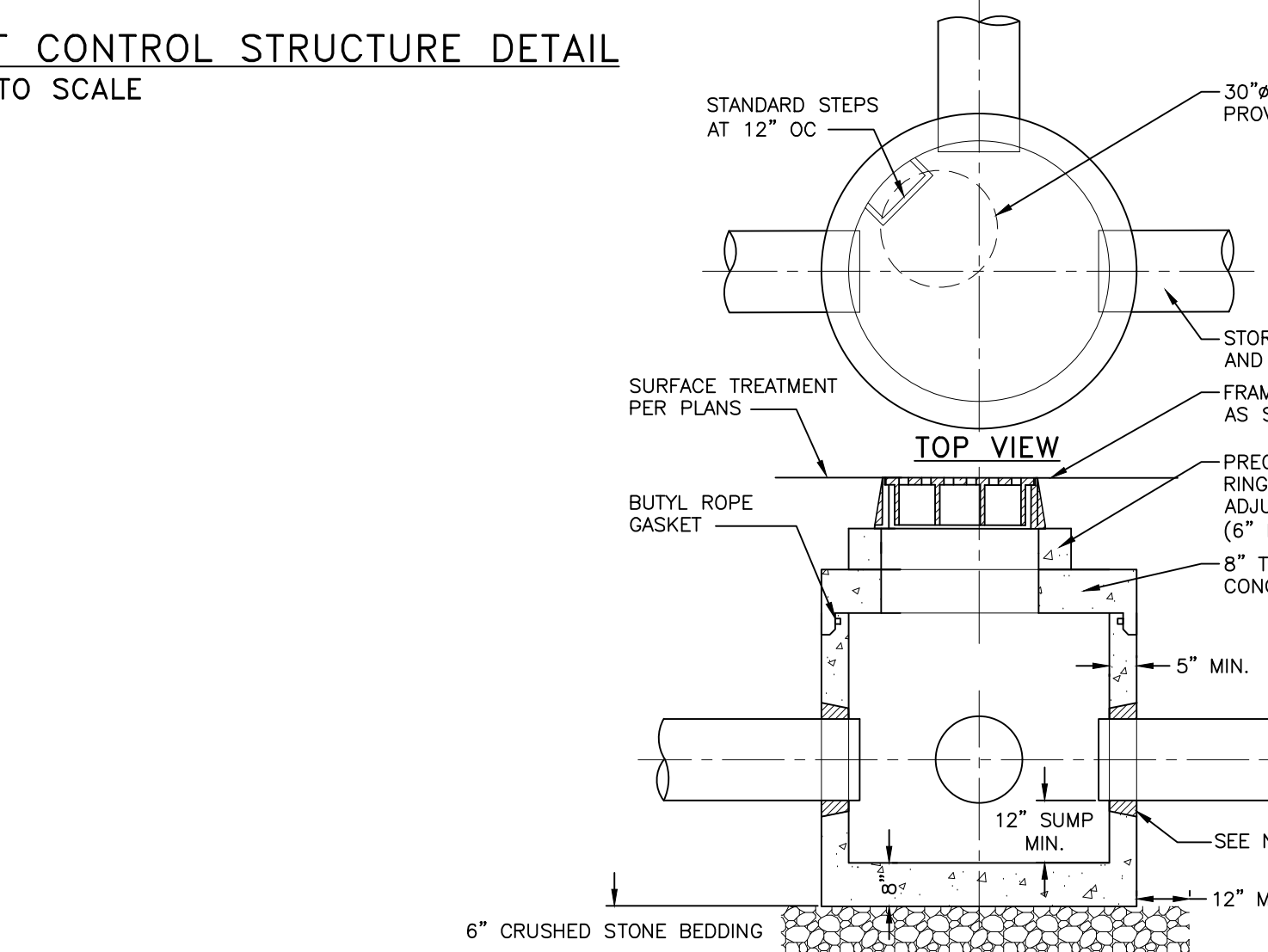
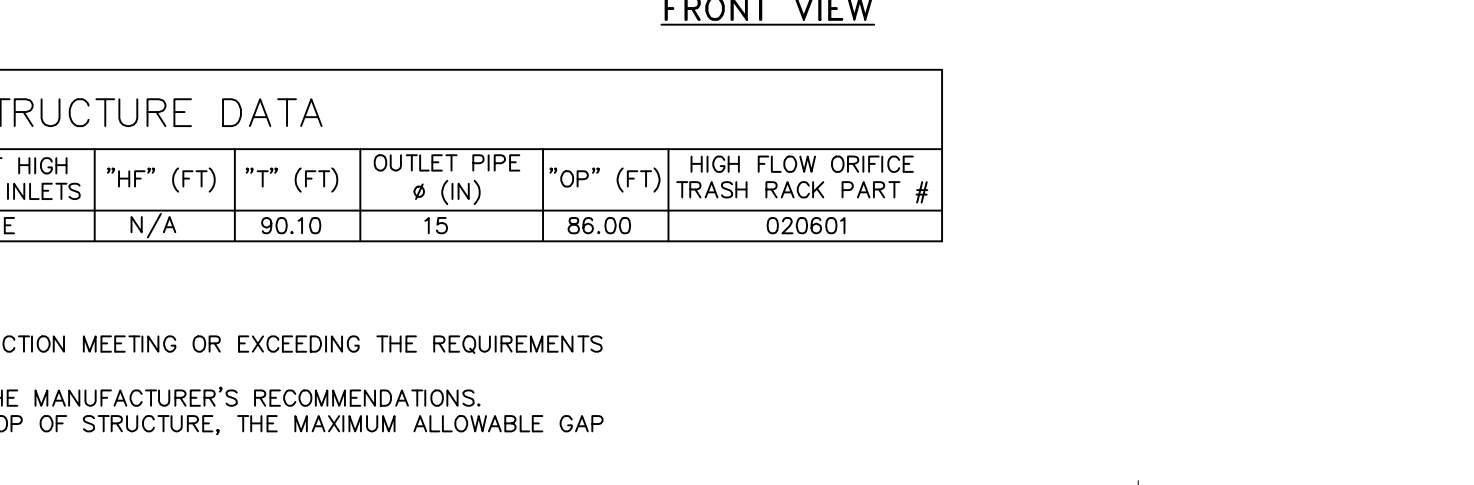
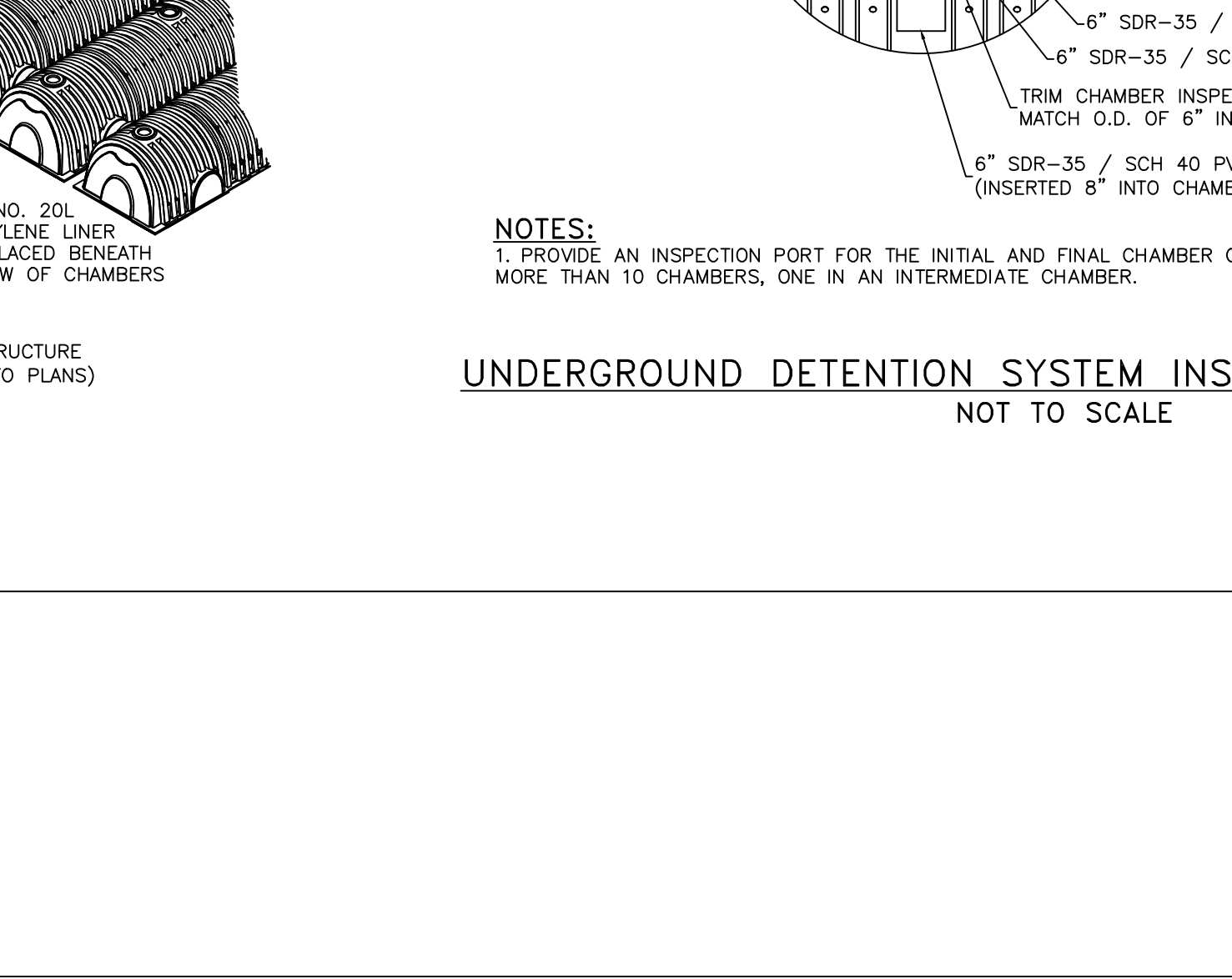
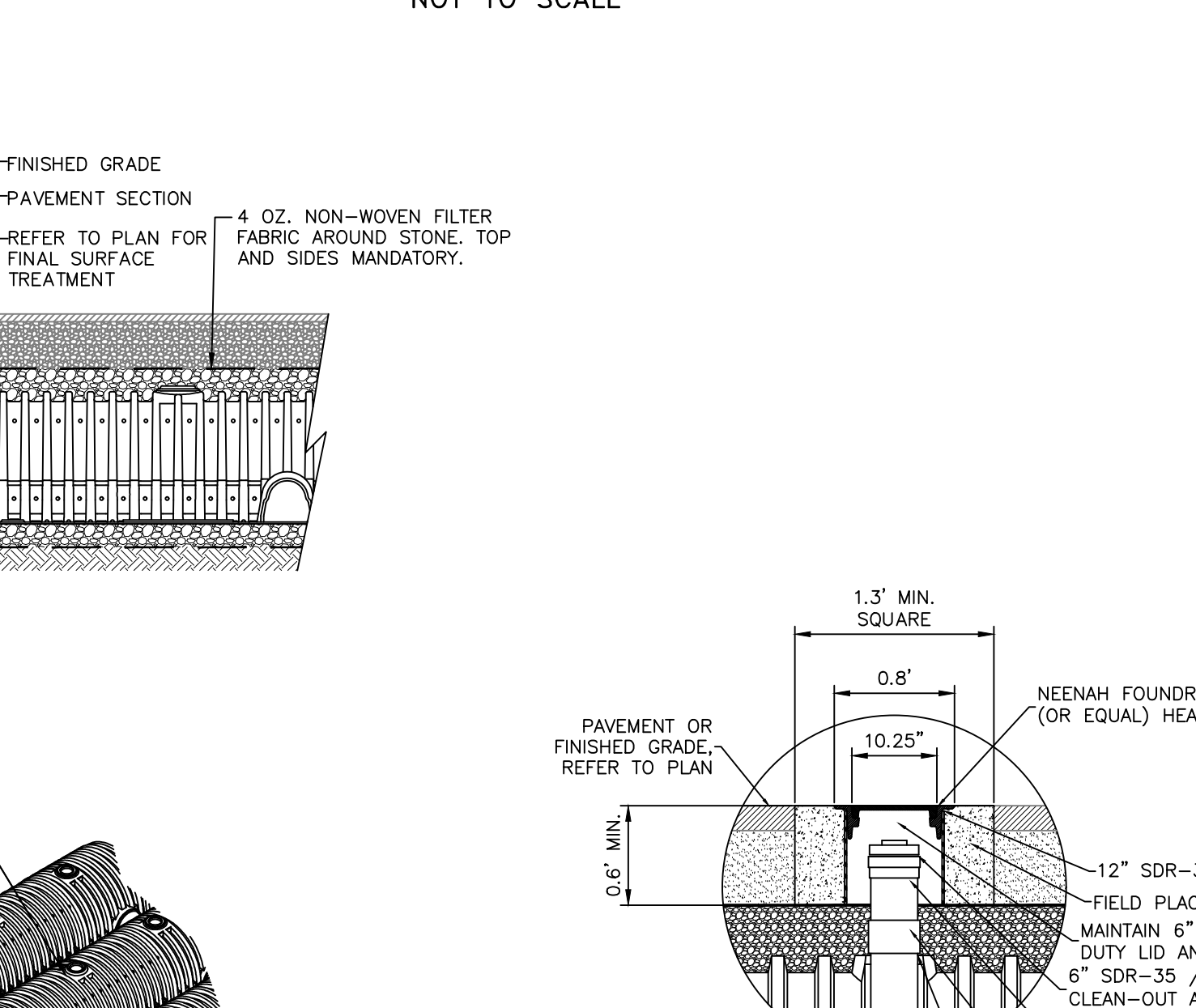
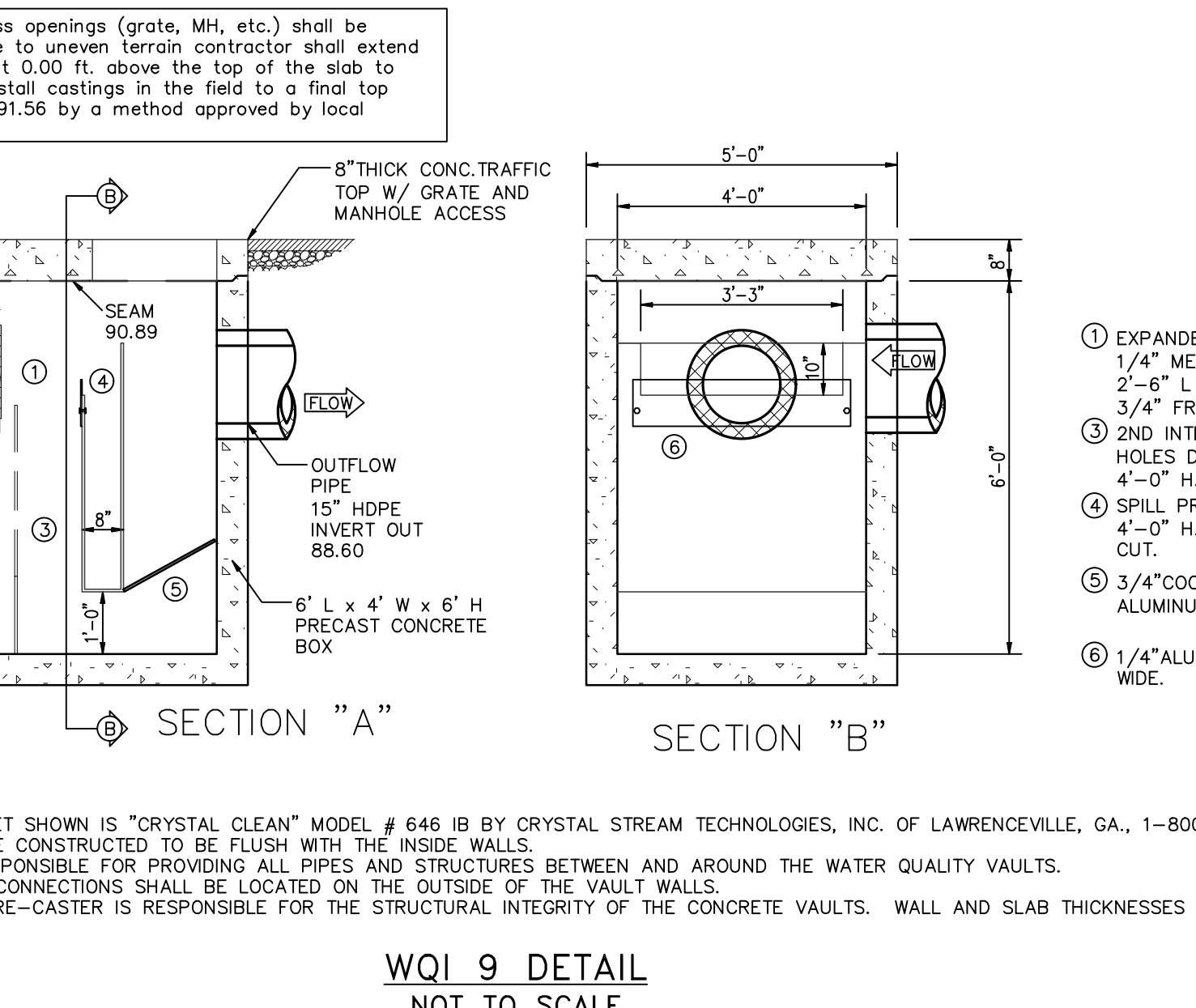
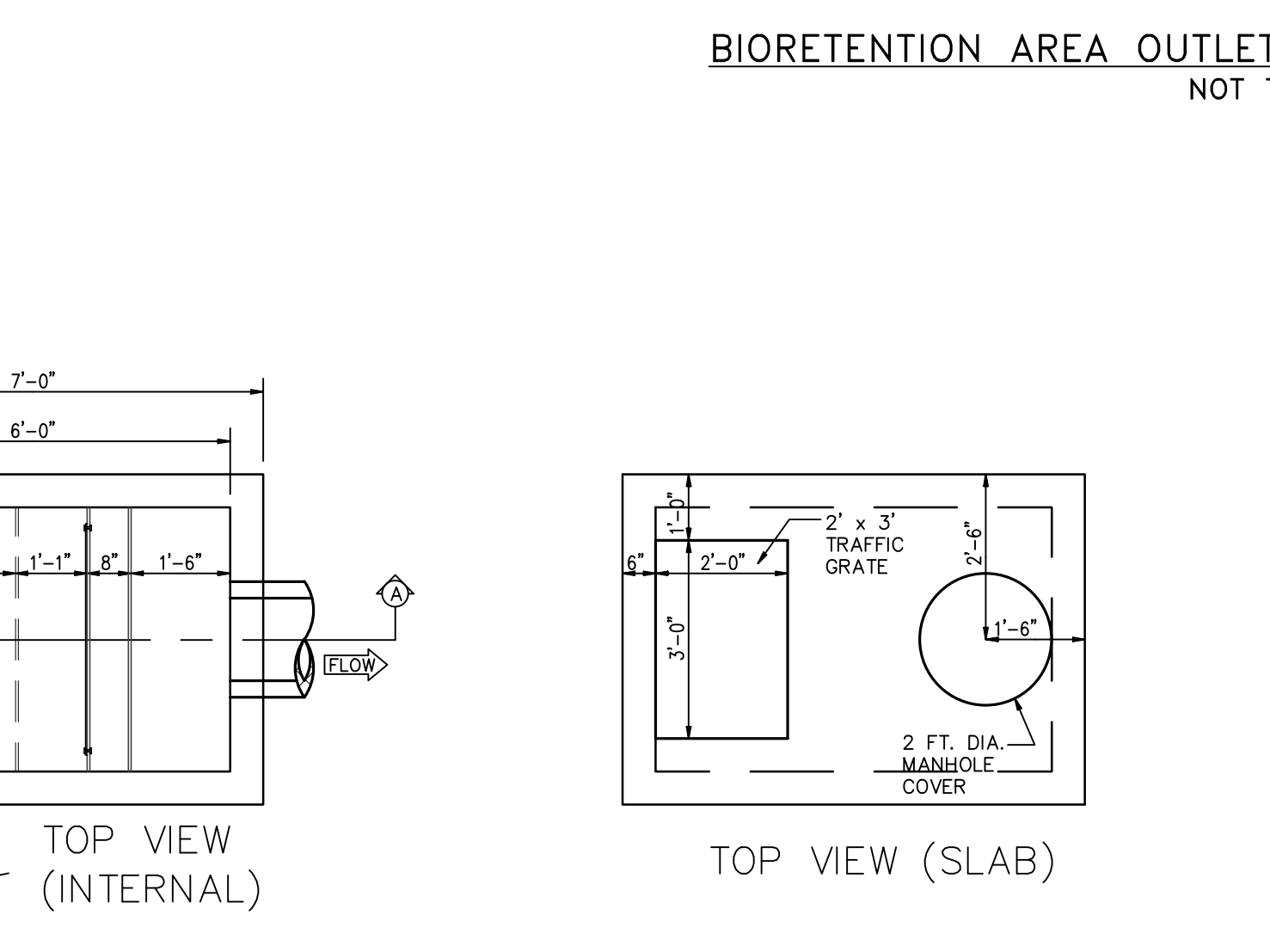
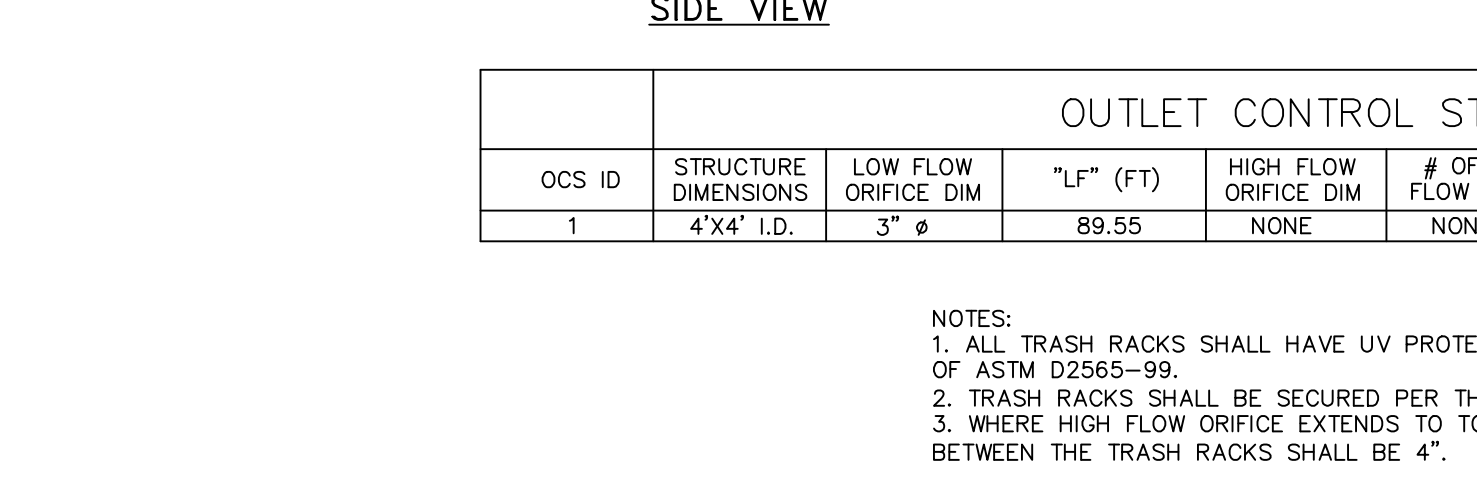
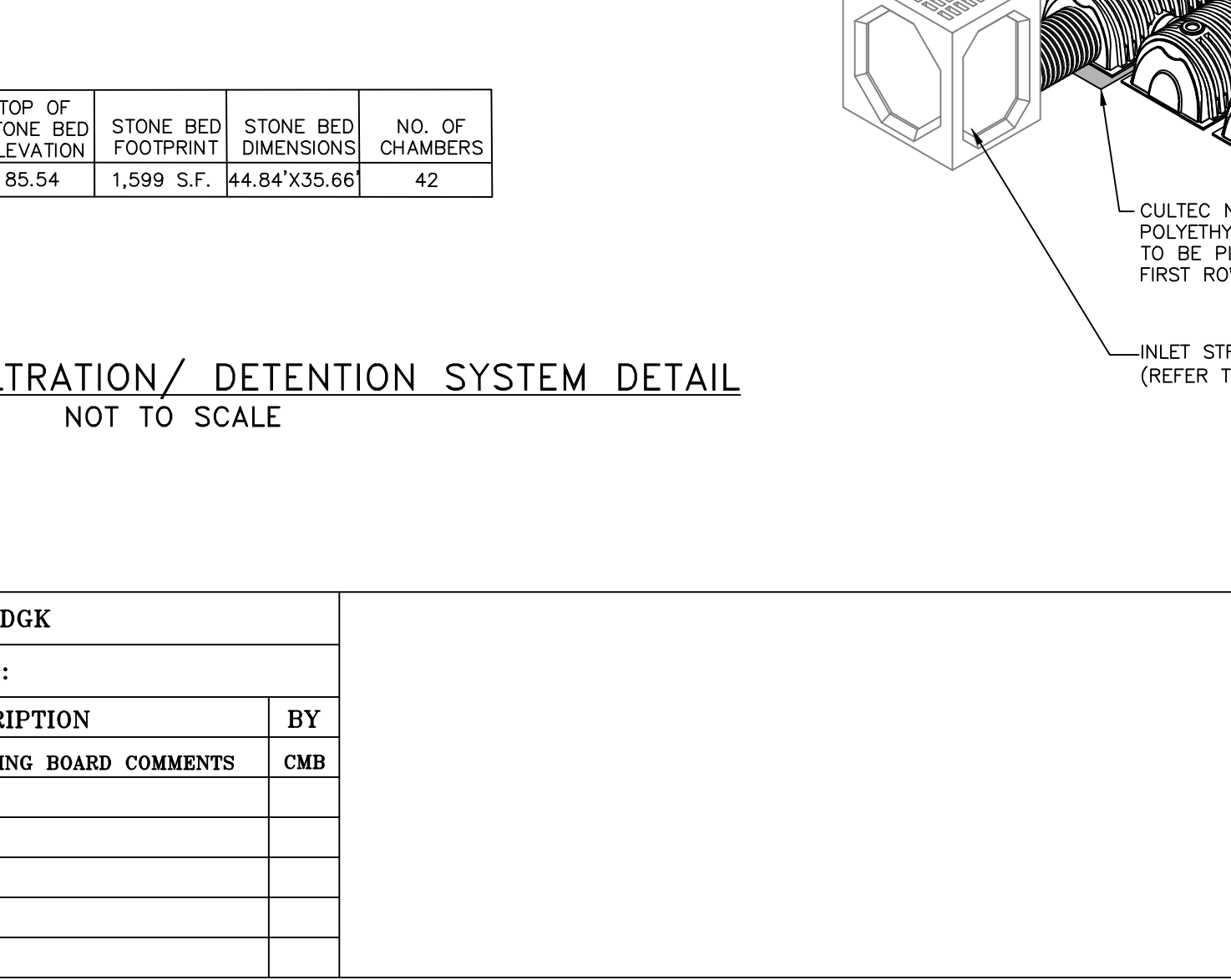
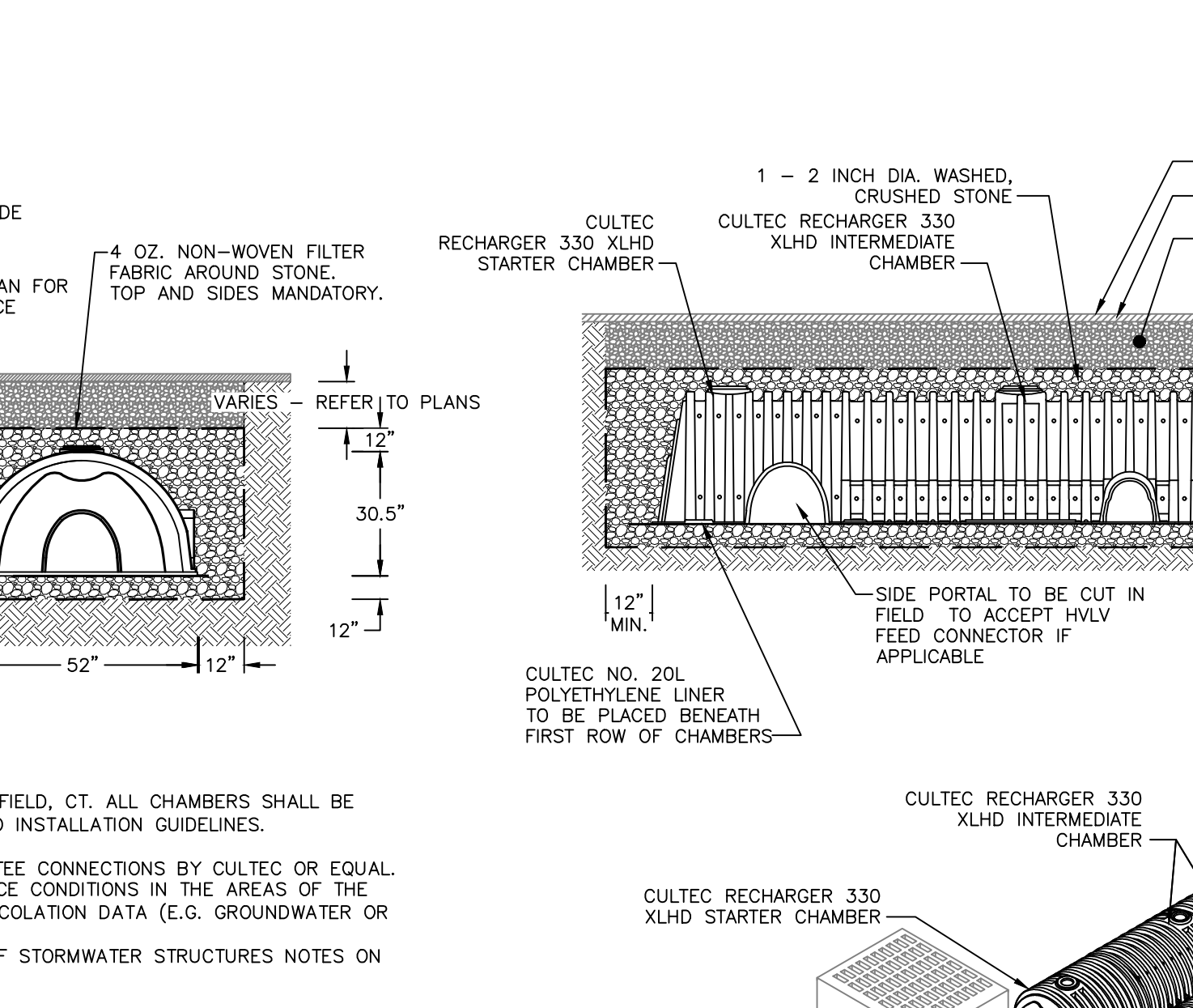
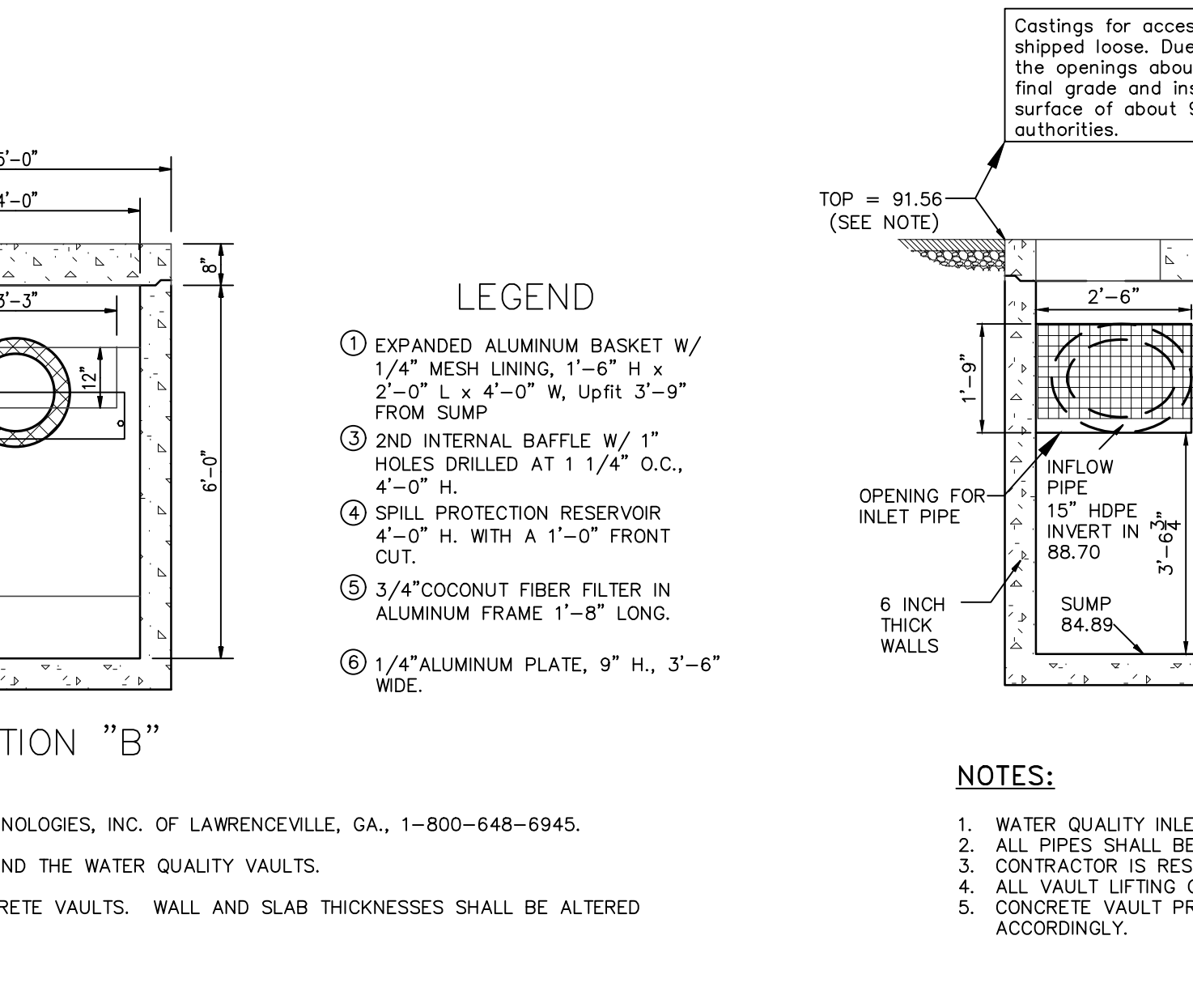
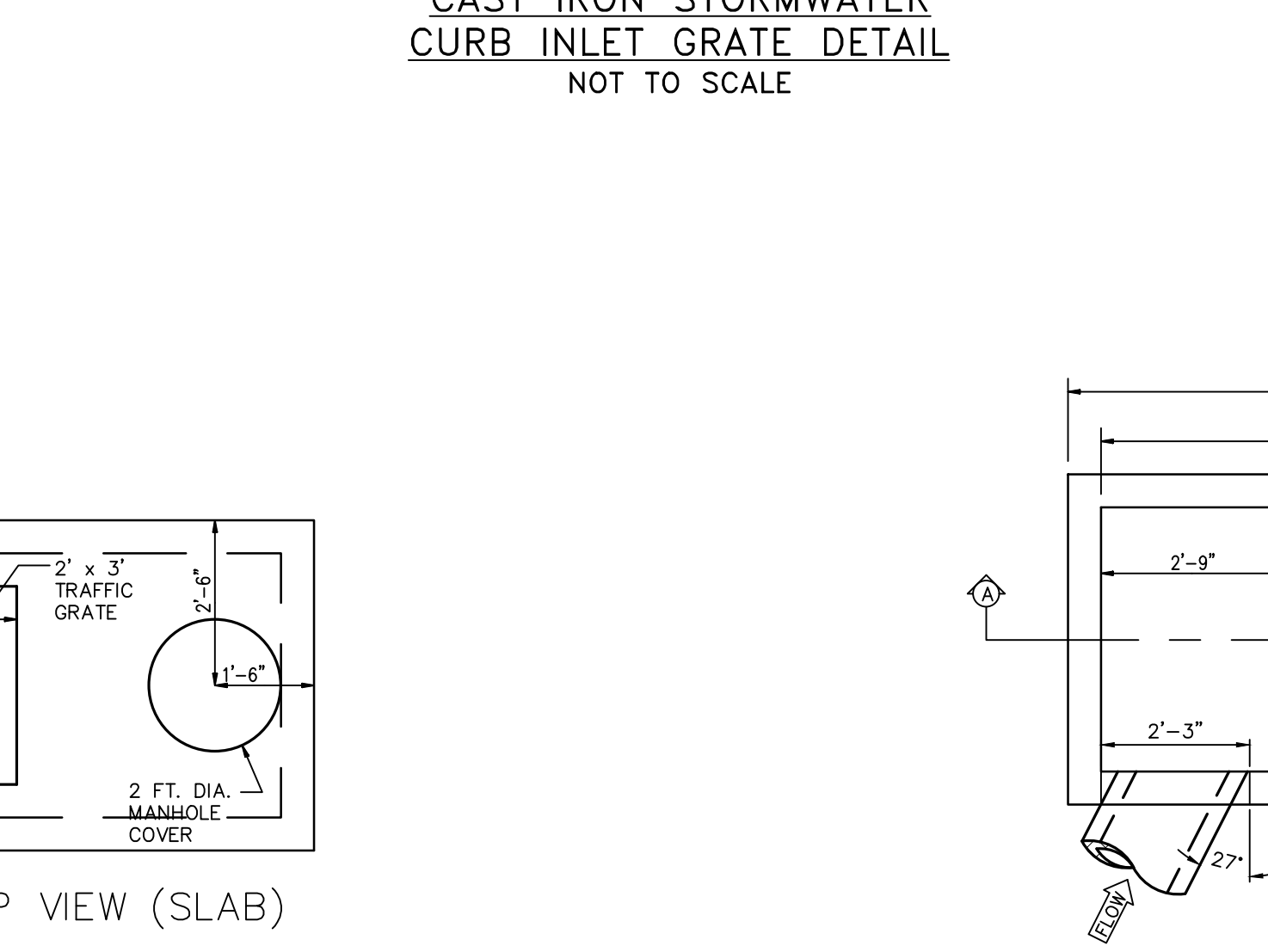
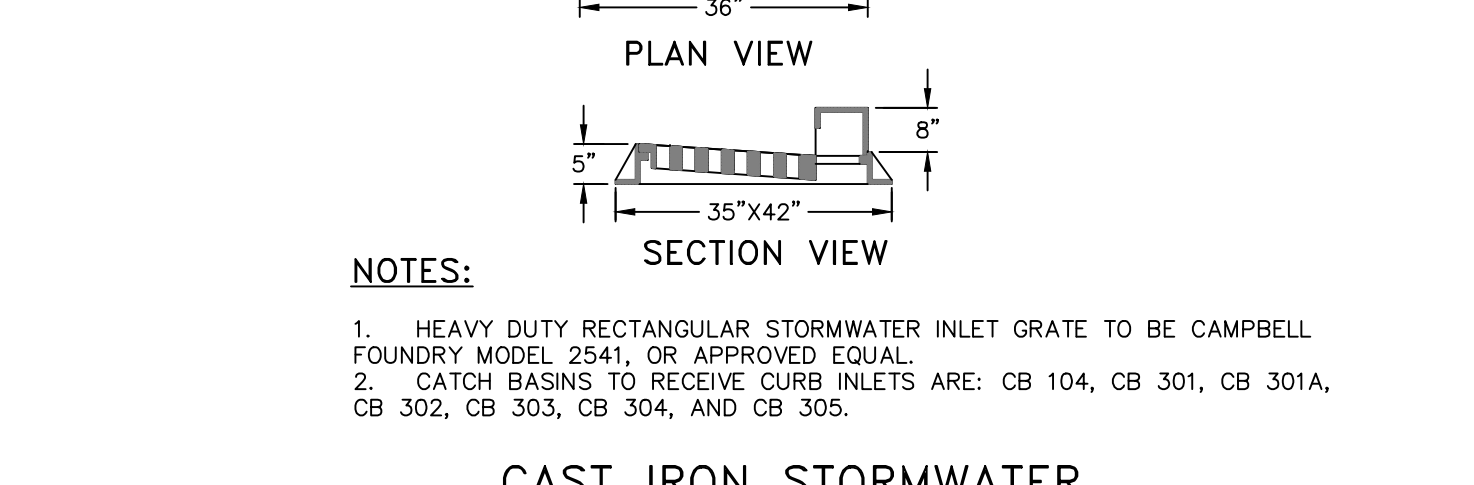

Dig Safely
800-962-7962
www.digsafely.com

HUDSON LAND DESIGN

STORMWATER DETAILS

23-28 CREEK DRIVE

23-28 CREEK ROAD
CITY OF BEACON
DUTCHESS COUNTY, NEW YORK
TAX ID: 6054-37-037825

JOB #: 2018-029
DATE: 10/23/2018
SCALE: AS SHOWN
TITLE: D-2
SHEET: 11 OF 12

UNAUTHORIZED ALTERATIONS OR ADDITIONS TO THIS DRAWING IS A VIOLATION OF SECTION 7209.2 OF THE NEW YORK EDUCATION LAW