

EROSION AND SEDIMENT CONTROL DETAILS

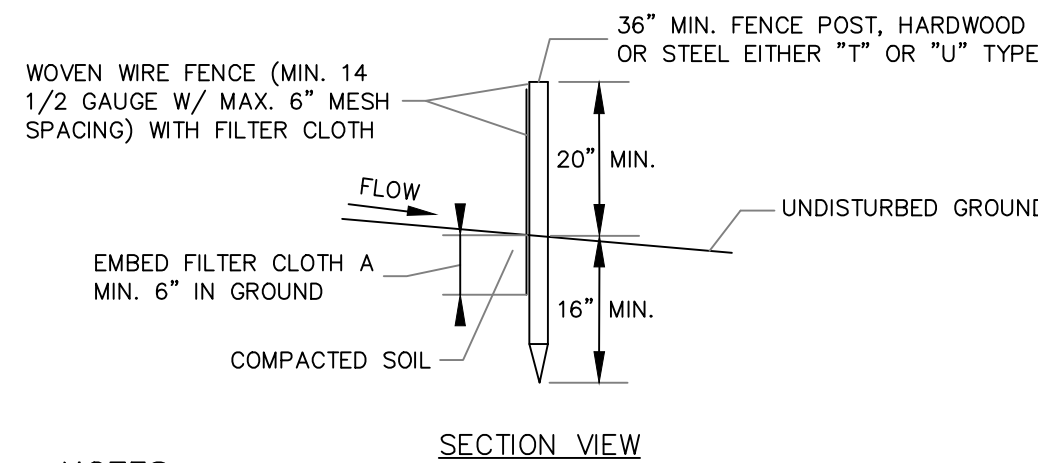

- NOTES:**
1. FILTER CLOTH TO BE FASTENED SECURELY TO WOVEN WIRE FENCE WITH TIES SPACED EVERY 24" AT TOP AND MID SECTION.
 2. WHEN TWO SECTIONS OF FILTER CLOTH ADJOIN EACH OTHER THEY SHALL BE OVER-LAPPED BY SIX INCHES AND FOLDED. FILTER CLOTH SHALL BE EITHER FILTER X, MIRAFI 100X, STABILINKA T140N OR APPROVED EQUAL.
 3. PREFABRICATED UNITS SHALL BE GEOFAB, ENVROFENCE OR APPROVED EQUAL.
 4. MAINTENANCE SHALL BE PERFORMED AS NEEDED AND MATERIAL REMOVED WHEN "BULGES" DEVELOP IN THE SILT FENCE.

SILT FENCE DETAIL
NOT TO SCALE

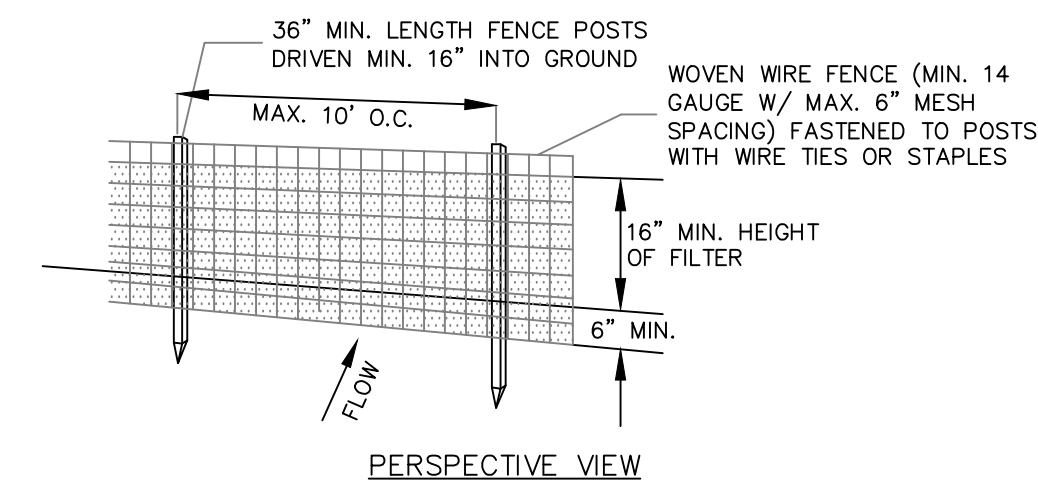
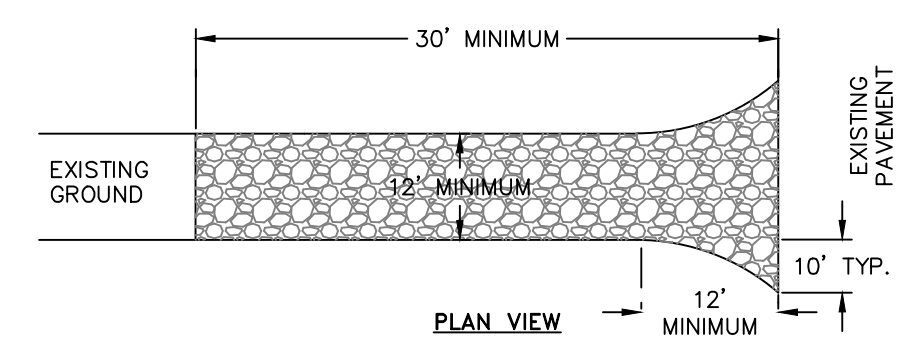

- NOTES:**
- 1) STONE SIZE - USE 1-4 INCH STONE, OR RECLAIMED OR RECYCLED CONCRETE EQUIVALENT.
 - 2) LENGTH - NOT LESS THAN 30 FEET FOR A SINGLE RESIDENCE LOT.
 - 3) THICKNESS - NOT LESS THAN SIX (6) INCHES.
 - 4) WIDTH - 12 FOOT MINIMUM, BUT NOT LESS THAN THE FULL WIDTH AT POINTS WHERE INGRESS OR EGRESS OCCURS. 24 FOOT MINIMUM IF SINGLE ENTRANCE TO SITE.
 - 5) GEOTEXTILE - WILL BE PLACED OVER THE ENTIRE AREA PRIOR TO PLACING OF STONE.
 - 6) SURFACE WATER - ALL SURFACE WATER FLOWING OR DIVERTED TOWARD CONSTRUCTION ENTRANCES SHALL BE PIPED BENEATH THE ENTRANCE. IF PIPING IS IMPRACTICAL, A MOUNTABLE BERM WITH 5:1 SLOPES WILL BE PERMITTED.
 - 7) MAINTENANCE - THE ENTRANCE SHALL BE MAINTAINED IN A CONDITION WHICH WILL PREVENT TRACKING OR FLOWING OF SEDIMENT ONTO PUBLIC RIGHTS-OF-WAY. THIS MAY REQUIRE PERIODIC TOP DRESSING WITH ADDITIONAL STONE AS CONDITIONS DEMAND AND REPAIR AND/OR CLEANOUT OF ANY MEASURE USED TO TRAP SEDIMENT. ALL SEDIMENT SPILLED, DROPPED, WASHED OR TRACTED ONTO PUBLIC RIGHTS-OF-WAY MUST BE REMOVED IMMEDIATELY.
 - 8) WHEN WASHING IS REQUIRED, IT SHALL BE DONE ON AN AREA STABILIZED WITH STONE AND WHICH DRAINS INTO AN APPROVED SEDIMENT TRAPPING DEVICE.
 - 9) PERIODIC INSPECTION AND NEEDED MAINTENANCE SHALL BE PROVIDED AFTER EACH RAIN.

STABILIZED CONSTRUCTION ENTRANCE DETAIL
NOT TO SCALE

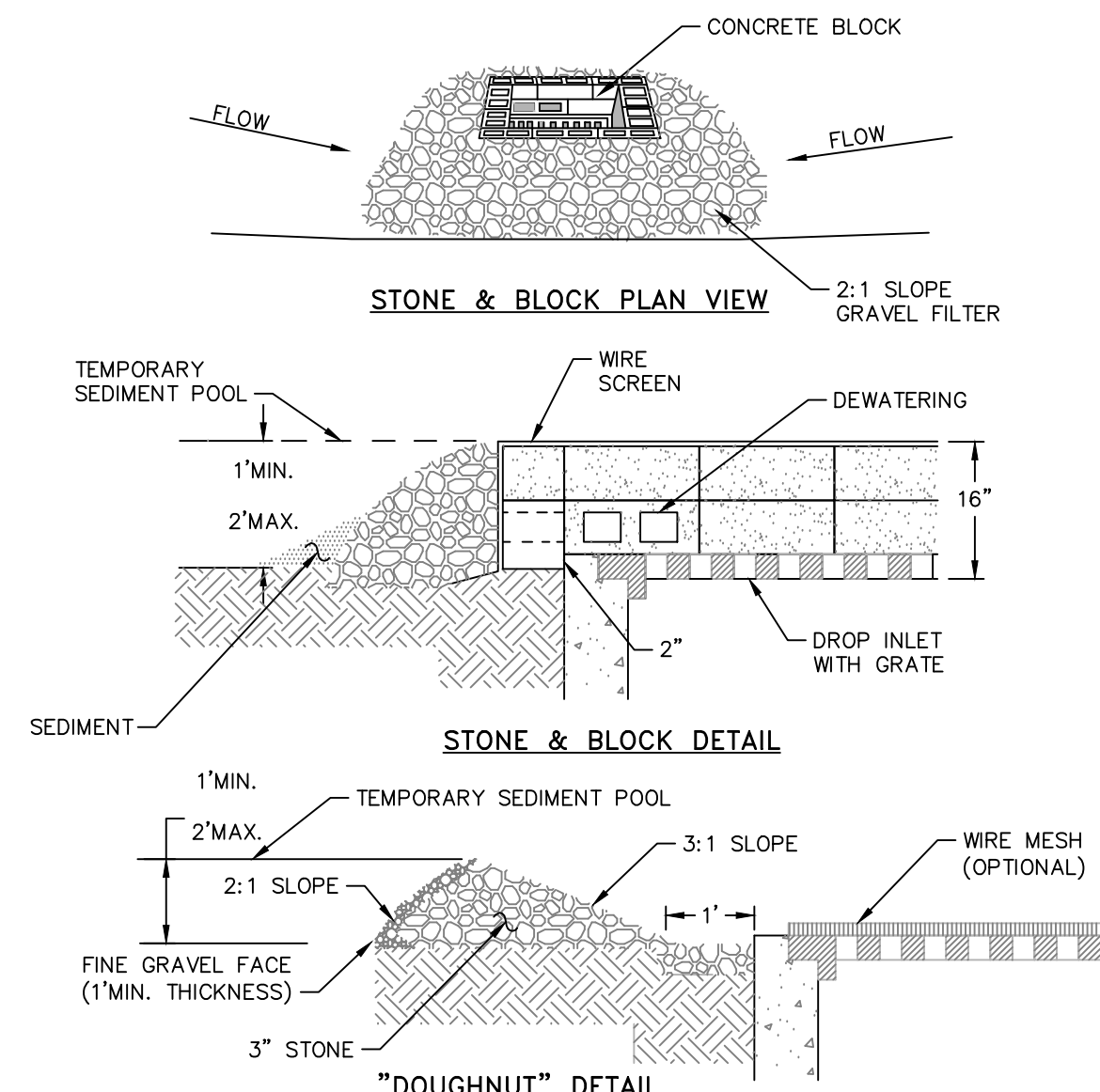

- NOTES:**
1. LAY ONE BLOCK ON EACH SIDE OF THE STRUCTURE ON ITS SIDE FOR DEWATERING. FOUNDATION SHALL BE 2 INCHES MINIMUM BELOW REST OF INLET AND BLOCKS SHALL BE PLACED AGAINST INLET FOR SUPPORT.
 2. HARDWARE CLOTH OR 1/2" WIRE MESH SHALL BE PLACED OVER BLOCK OPENINGS TO SUPPORT STONE.
 3. USE CLEAN STONE OR GRAVEL 1/2-3/4 INCH IN DIAMETER PLACED 2 INCHES BELOW TOP OF THE BLOCK ON A 2:1 SLOPE OR FLATTER.
 4. FOR STONE STRUCTURES ONLY, A 1 FOOT THICK LAYER OF THE FILTER STONE WILL BE PLACED AGAINST THE 3 INCH STONE AS SHOWN ON THE DRAWINGS. MAXIMUM DRAINAGE AREA 1 ACRE.

CATCH BASIN INLET PROTECTION DETAIL
NOT TO SCALE

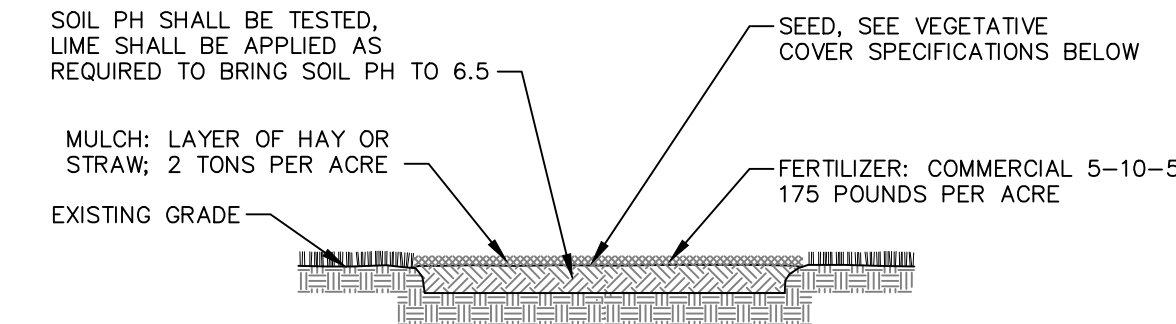

- NOTES:**
1. TOPSOIL, SEED, MULCH, AND FERTILIZE DISTURBED SOIL AREAS THAT WILL BE LEFT EXPOSED FOR 14 DAYS OR MORE.
 2. SEED MIXTURE FOR USE ON LAWNS IN SUNNY AREAS:
65% KENTUCKY BLUE GRASS BLEND 114 POUNDS PER ACRE
20% PERENNIAL RYEGRASS 35 POUNDS PER ACRE
15% FINE FESCUE 28 POUNDS PER ACRE
175 POUNDS PER ACRE
 3. SEED MIXTURE FOR USE IN SHADY AREAS:
80% BLEND OF SHADE TOLERANT KENTUCKY BLUEGRASS 138 POUNDS PER ACRE
20% FINE FESCUE 37 POUNDS PER ACRE
175 POUNDS PER ACRE
 4. SEED BETWEEN APRIL 1ST AND MAY 15TH OR AUGUST 15TH AND OCTOBER 15TH. SEEDING MAY OCCUR BETWEEN MAY 15TH AND AUGUST 15TH IF ADEQUATE IRRIGATION IS PROVIDED.
 5. TOPSOIL SHALL HAVE AT LEAST 6% BY WEIGHT OF FINE TEXTURED STABLE ORGANIC MATERIAL, AND NO GREATER THAN 20%. TOPSOIL SHALL HAVE NOT LESS THAN 20% FINE TEXTURED MATERIAL (PASSING THE NO. 200 SIEVE) AND NOT MORE THAN 15% CLAY.

TOPSOIL, SEED AND MULCH DETAIL
NOT TO SCALE

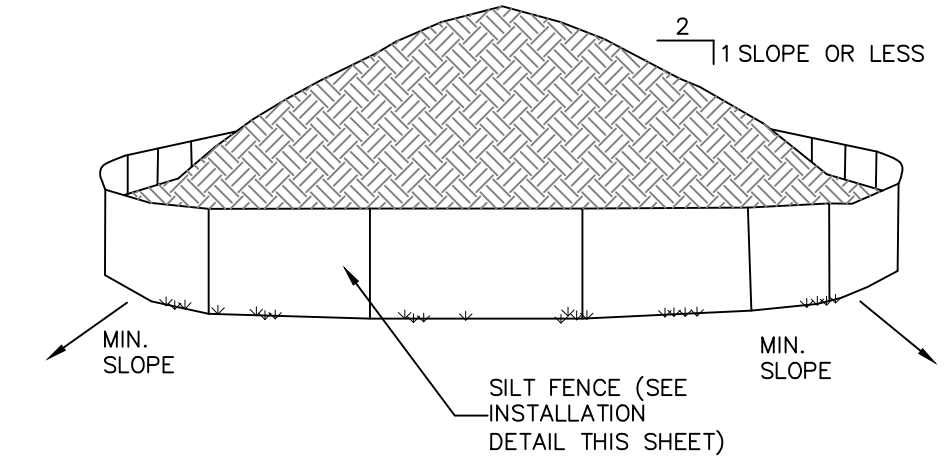

- NOTES:**
1. AREA CHOSEN FOR STOCKPILING OPERATIONS SHALL BE DRY AND STABLE.
 2. EACH PILE SHALL BE SURROUNDED WITH SILT FENCING, THEN STABILIZED WITH VEGETATION OR COVERED.

STORMWATER DETAILS

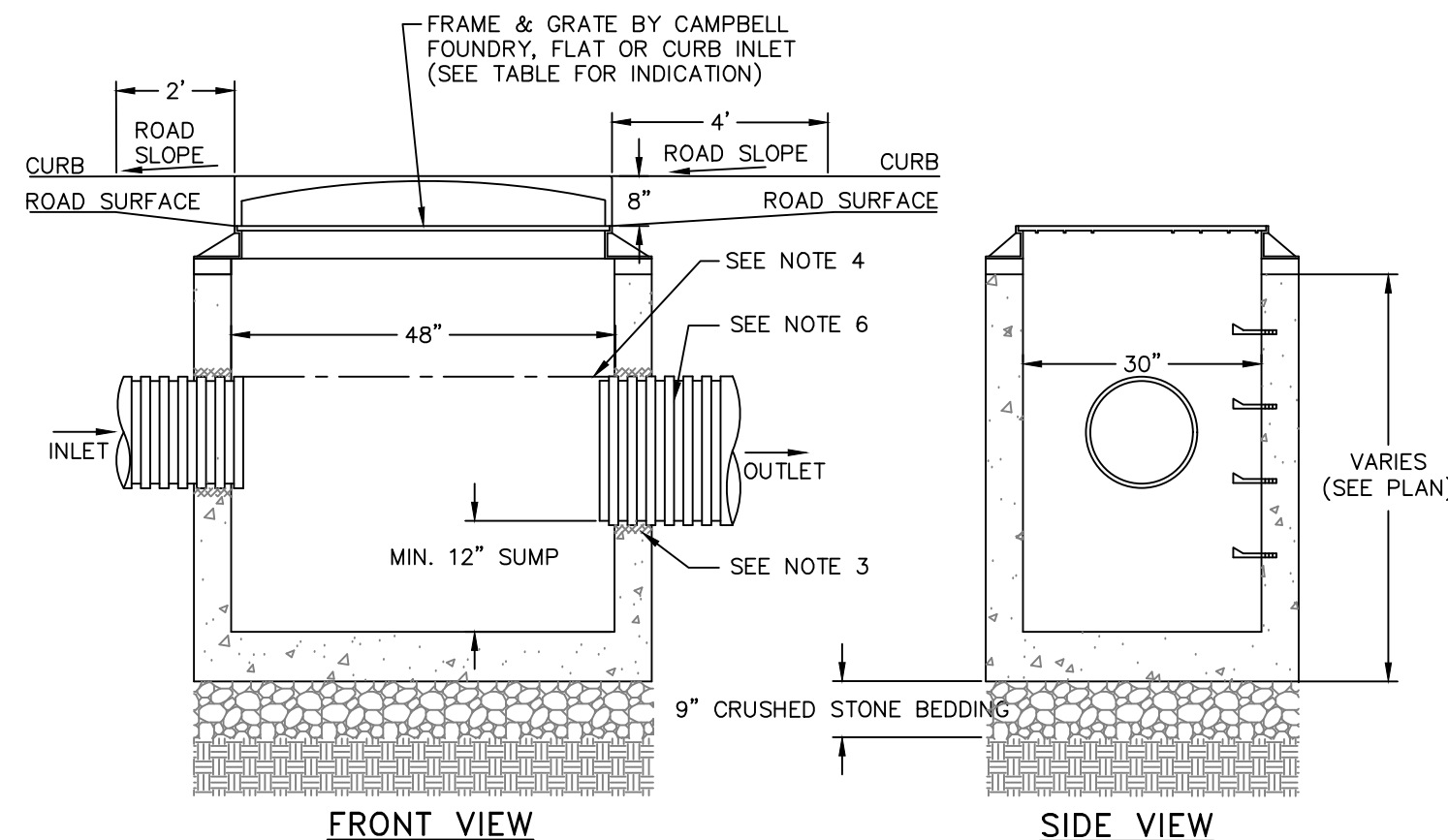

- NOTES:**
1. PRECAST CONCRETE CATCH BASIN WITH CONCRETE STRENGTH OF 4,000 PSI @ 28 DAYS.
 2. THE ENDS OF ALL PIPES SHALL BE CUT OFF FLUSH WITH THE INSIDE SURFACE OF THE CATCH BASIN AND PARGED AROUND.
 3. PIPES SHALL BE PARGED AROUND INTERIOR AND EXTERIOR PRIOR TO BACKFILLING OF STRUCTURE. CONNECTIONS MADE WITHIN 10 FEET OF A WATER MAIN (OR SERVICE LINE) OR A SEWER MAIN (OR SERVICE LATERAL) SHALL BE MADE WATERTIGHT.
 4. PROVIDE A MINIMUM 0.1' DROP BETWEEN INLET AND OUTLET INVERTS (MATCH CROWNS FOR PIPES WITH DIFFERENT SIZE) UNLESS OTHERWISE NOTED ON THE PLAN.
 5. CATCH BASINS WITH AN INTERIOR DEPTH OF 4' AND GREATER SHALL BE FURNISHED WITH STEEL REINFORCED POLYPROPYLENE PLASTIC STEPS AT 12" INTERVALS.
 6. HDPE PIPE SHALL BE PROVIDED WITH WATERTIGHT CONNECTIONS. ADS MODEL N12 WT IB OR APPROVED EQUAL.

CATCH BASIN DETAIL
NOT TO SCALE

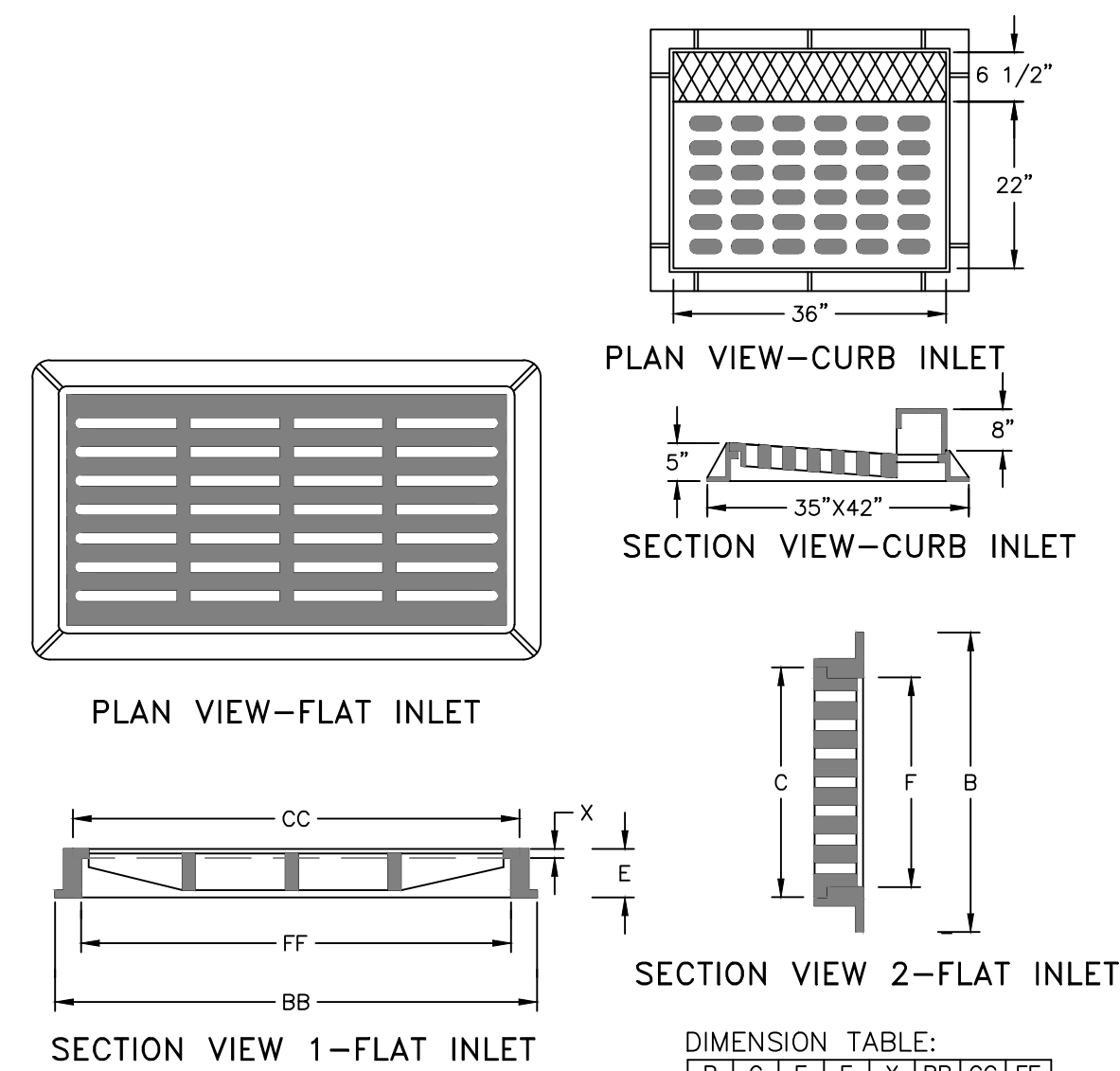

- NOTES:**
1. HEAVY DUTY RECTANGULAR STORMWATER FLAT INLET GRATE TO BE CAMPBELL FOUNDRY MODEL 3433, OR APPROVED EQUAL.
 2. HEAVY DUTY RECTANGULAR STORMWATER CURB INLET GRATE TO BE CAMPBELL FOUNDRY MODEL 2541, OR APPROVED EQUAL.

CAST IRON STORMWATER FLAT AND CURB INLET GRATE DETAIL
NOT TO SCALE

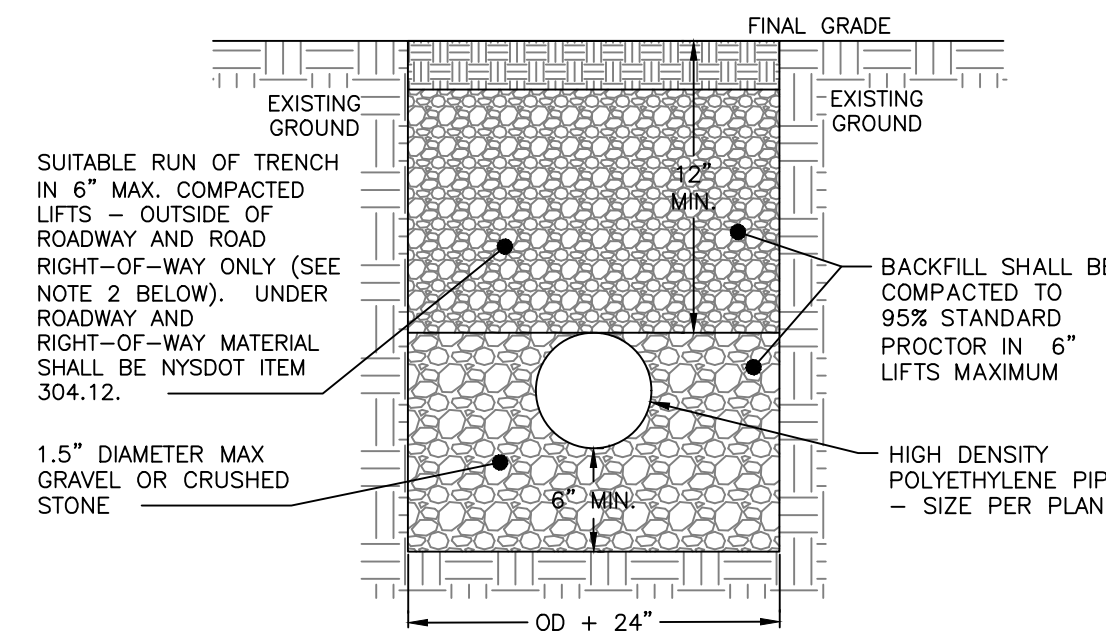

- NOTES:**
1. EXCAVATION AND TRENCHING SHALL MEET ALL OSHA REQUIREMENTS.

STORM LINE TRENCH DETAIL
NOT TO SCALE

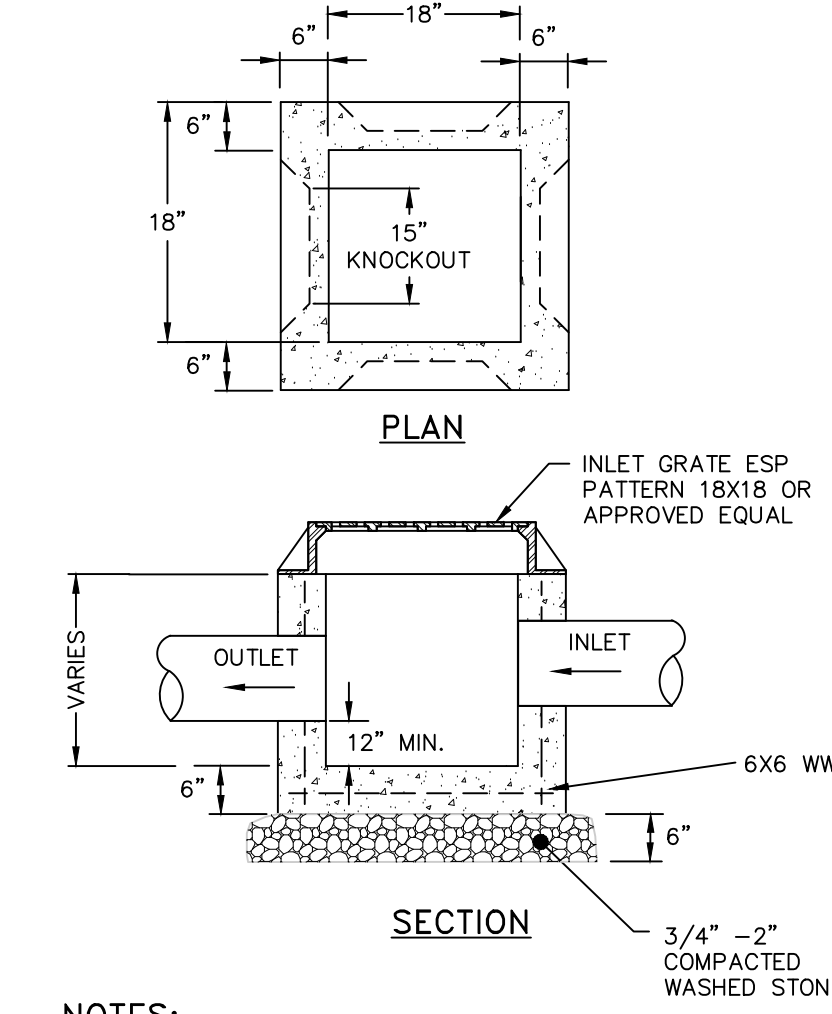

- NOTES:**
1. YARD INLET BASINS SHALL BE PRE CAST REINFORCED CONCRETE SHALL HAVE A MINIMUM 28-DAY COMPRESSIVE STRENGTH OF 4,000 PSI AND SHALL BE IN CONFORMANCE WITH ASTM 478-68. WALLS AND BASE SHALL BE ONE PIECE CONSTRUCTION. YARD INLET BASIN SHOWN BY EXPANDED SUPPLY PRODUCTS (ESP), 3330 ROUTE 9, COLD SPRING, NY (845) 265-3771.
 2. BACKFILL USING SELECT MATERIAL, COMPACTED IN 6" LIFTS.
 3. SUMP SHALL BE 12" DEEP.
 4. FRAMES AND GRATES SHALL BE SET IN A FULL BED OF MORTAR.

PRE-CAST CONCRETE YARD INLET DETAIL
NOT TO SCALE

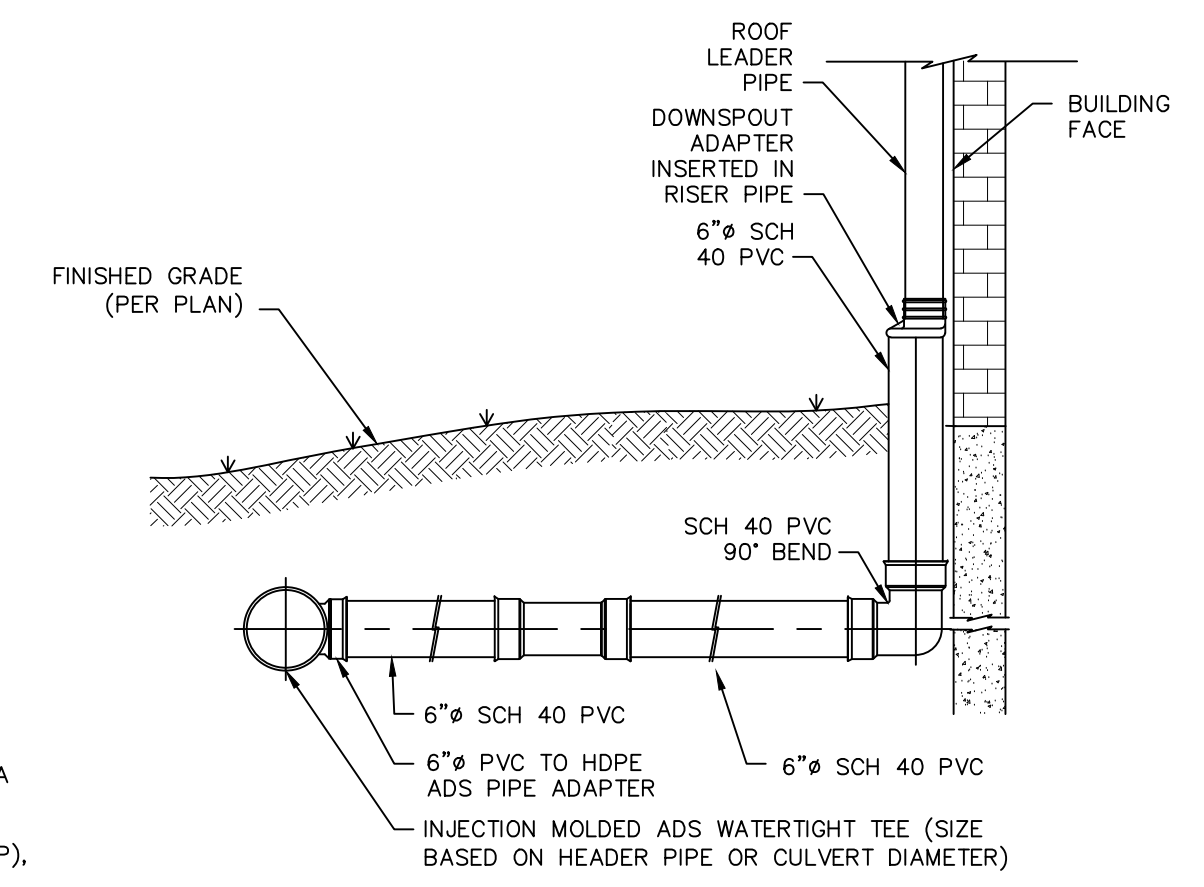

- NOTES:**
1. ROOF LEADER LOCATIONS AND SIZES TO BE DETERMINED BY THE PROJECT ARCHITECT. DOWNSPOUT ADAPTER TO MATCH DOWNSPOUT SIZE.
 2. PVC JOINT CONNECTIONS SHALL BE MADE WITH PVC CEMENT.
 3. ROOF DRAINAGE HEADER PIPES SHALL BE AS NOTED ON THE UTILITY SHEET.
 4. SUBSTITUTIONS OF PIPE MATERIAL SHALL BE BROUGHT TO THE DESIGN ENGINEER'S ATTENTION FOR REVIEW.

ROOF LEADER CONNECTION DETAIL
NOT TO SCALE

DRAWN BY: CMB				CHECKED BY: MAB			
REVISIONS:				REVISIONS:			
NO.	DATE	DESCRIPTION	BY	NO.	DATE	DESCRIPTION	BY
2	3/26/19	ADDED SHEET	CMB				
3	4/30/19	PER PLANNING BOARD COMMENTS	CMB				
4	5/28/19	PER PLANNING BOARD COMMENTS	ESR				
5	6/25/19	NO CHANGES THIS SHEET	AG				



HUDSON LAND DESIGN
PROFESSIONAL ENGINEERING P.C.
174 MAIN ST., BEACON, NEW YORK 12508
13 CHAMBERS ST., NEWBURGH, NEW YORK 12550
PH: 845-440-6926
P: 845-440-6637

STORMWATER & EROSION AND SEDIMENT CONTROL DETAILS

53 ELIZA STREET

53 ELIZA STREET
CITY OF BEACON
DUTCHESS COUNTY, NEW YORK
TAX ID: 6054-29-031870

JOB #: 2018-032

DATE: 8/28/18

SCALE: 1"=20'

TITLE: CD-2

SHEET: 11 OF 13