

- NOTES:**
- EXCAVATION AND TRENCHING SHALL MEET ALL OSHA REQUIREMENTS.
 - SUITABLE RUN OF TRENCH SHALL NOT INCLUDE FROZEN MATERIALS, DEBRIS, ORGANIC MATERIALS, ENLARGED PARTICLES, LARGE STONES OR OTHER UNSUITABLE MATERIALS. IF THE RUN OF TRENCH MATERIAL IS FOUND TO BE UNSUITABLE, A SUITABLE BACKFILL MATERIAL SHALL BE IMPORTED AND USED.
 - IN AREAS WHERE 5' COVER REQUIREMENT CANNOT BE MET, THE CONTRACTOR SHALL PROVIDE PIPE INSULATION TO PREVENT FREEZING.

WATER SERVICE LINE TRENCH DETAIL
NOT TO SCALE

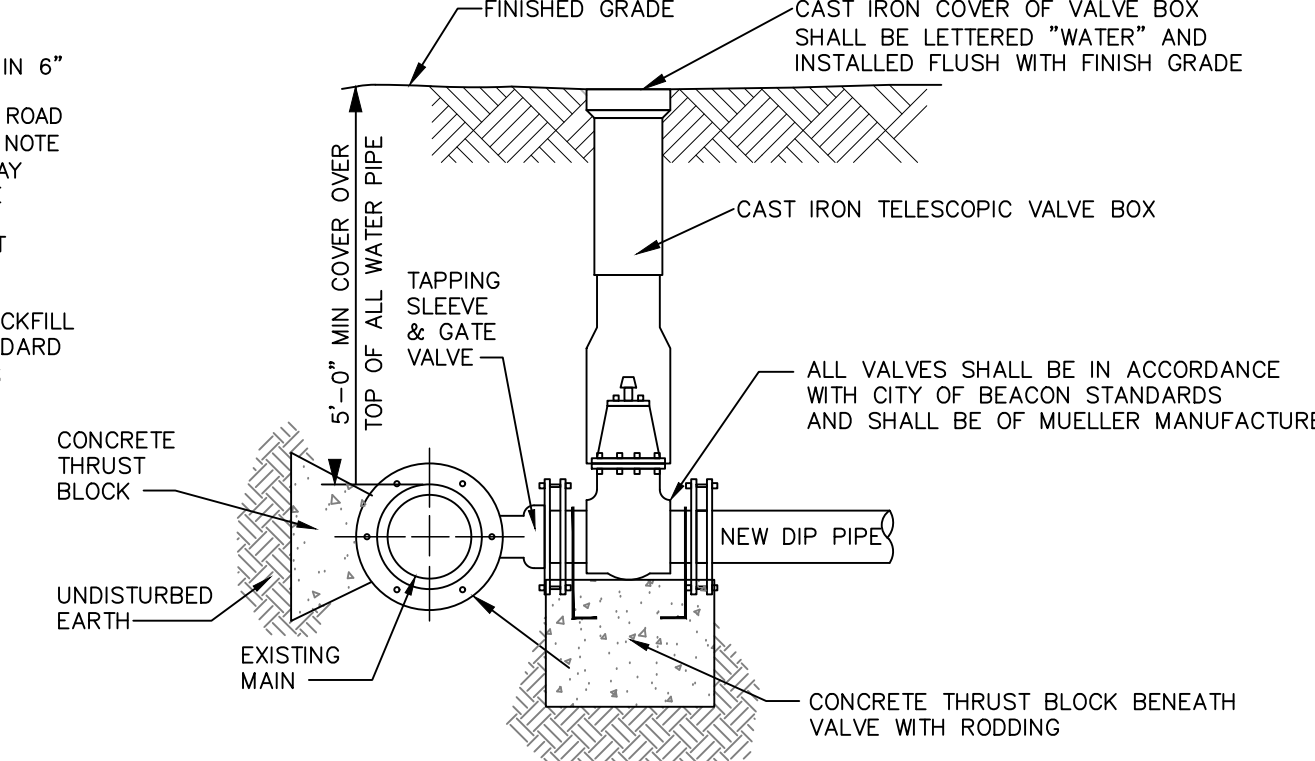

- NOTES:**
- ALL VALVES SHALL OPEN BY TURNING LEFT (COUNTERCLOCKWISE) AND HAVE A 2-INCH SQUARE OPERATING NUT PAINTED RED.
 - ALL VALVES SHALL BE M.J. RESILIENT WEDGE TYPE WITH "O" RING PACKING, DESIGNED FOR A WORKING PRESSURE OF 150 PSI AND BE IN FULL CONFORMANCE WITH AWWA C500.
 - TAPPING SLEEVE AND GATE VALVE SHOWN ARE MUELLER H-615, AND T-2630 RESPECTIVELY.

TAPPING SLEEVE DETAIL
NOT TO SCALE

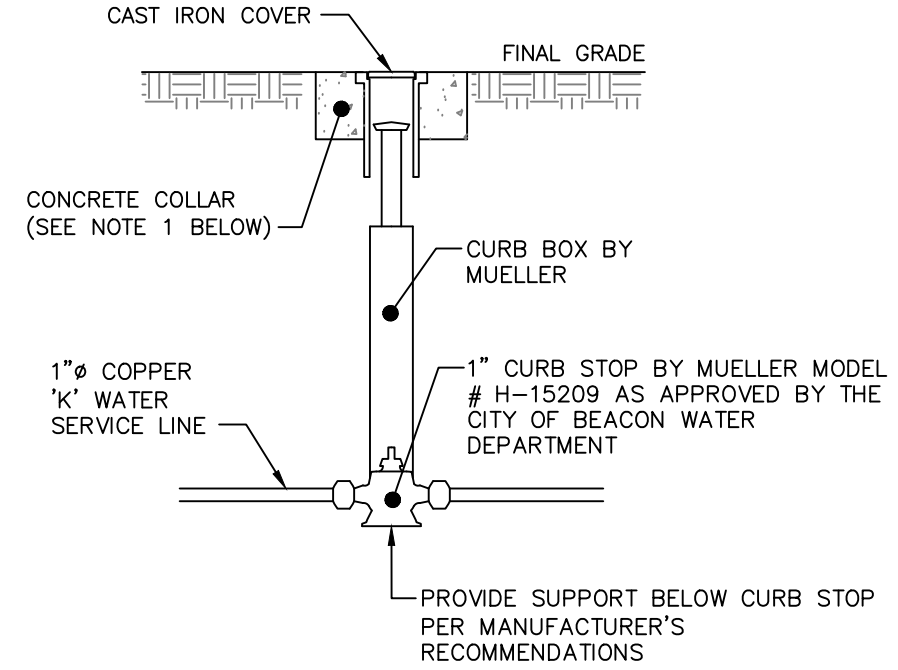

- NOTES:**
- CONCRETE COLLAR TO BE PROVIDED IN AREAS THAT ARE NOT PAVED. THE COLLAR SHALL BE 6" FROM THE COVER AND SHALL EXTEND 6" BELOW FINAL GRADE.
 - CURB STOP TO BE COMPRESSION TYPE BY MUELLER.
 - AREA AROUND CURB BOX TO BE BACKFILLED WITH GRAVELLY MATERIAL.

WATER SHUT-OFF VALVE DETAIL
NOT TO SCALE

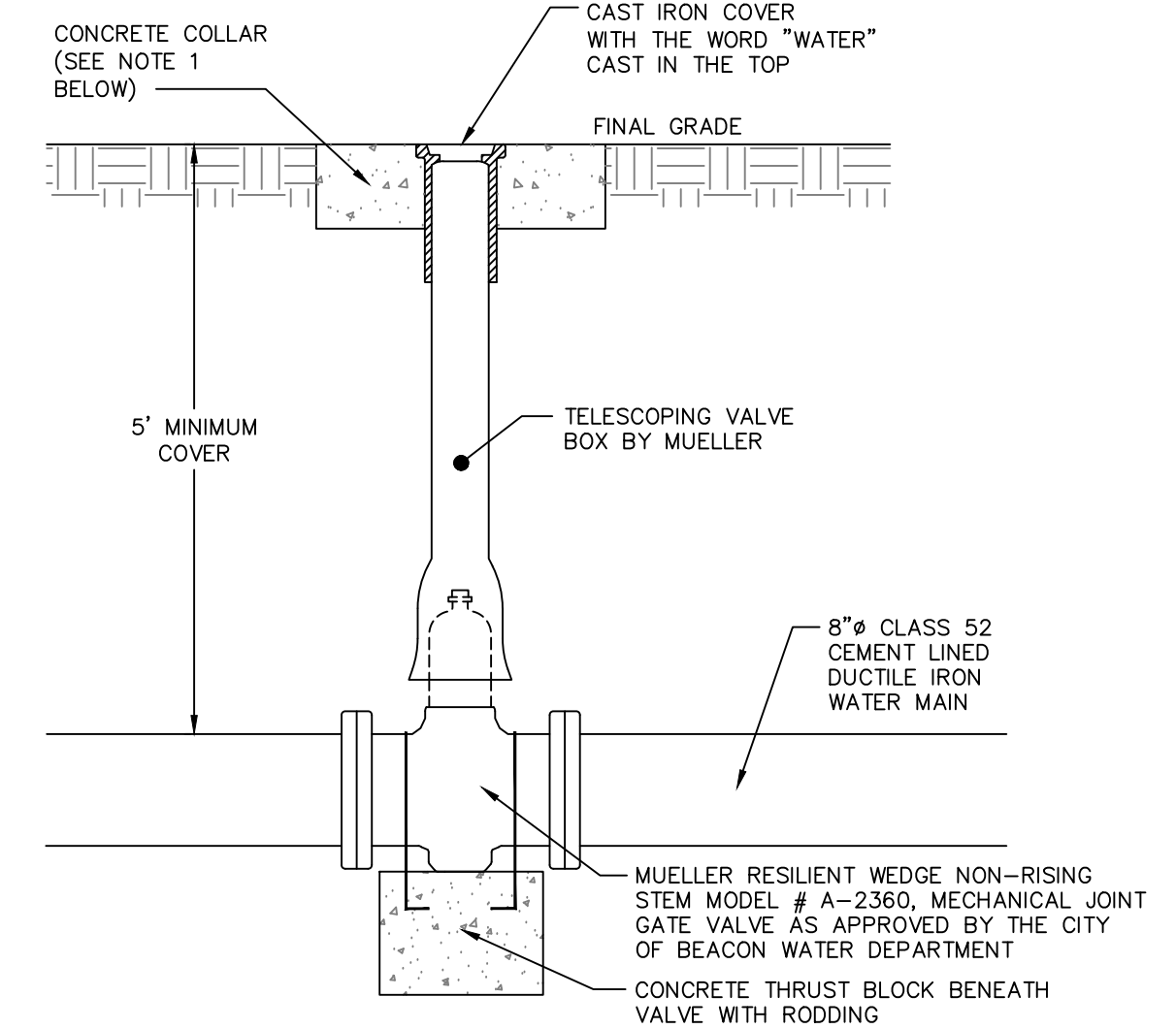

- NOTES:**
- CONCRETE COLLAR TO BE PROVIDED IN AREAS THAT ARE NOT PAVED. THE COLLAR SHALL BE 6" FROM THE COVER AND SHALL EXTEND 6" BELOW FINAL GRADE.

GATE VALVE DETAIL
NOT TO SCALE

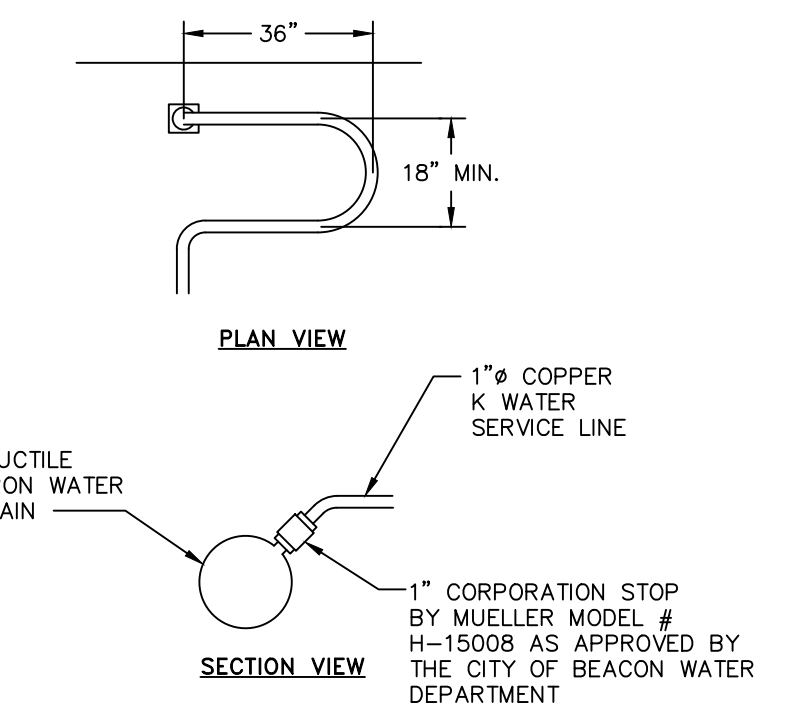

- NOTES:**
- A MINIMUM 5' COVER SHALL BE PROVIDED ON THE WATER SERVICE LINE (CONDITIONED ON ACTUAL WATER MAIN DEPTH).
 - CORPORATION STOP TO BE COMPRESSION TYPE BY MUELLER.
 - WATER SERVICE LINE TO HAVE A "GOOSENECK" NEAR CORPORATION STOP.
 - CORPORATION STOP TO BE INSTALLED IN THE UPPER HALF OF THE HORIZONTAL.

WATER SERVICE CONNECTION DETAIL
NOT TO SCALE

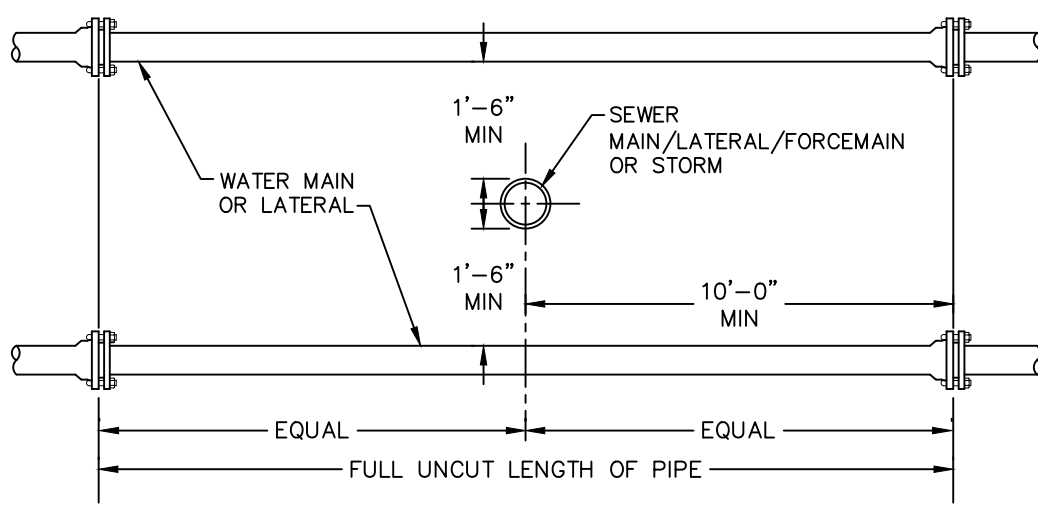

VERTICAL SEPARATION

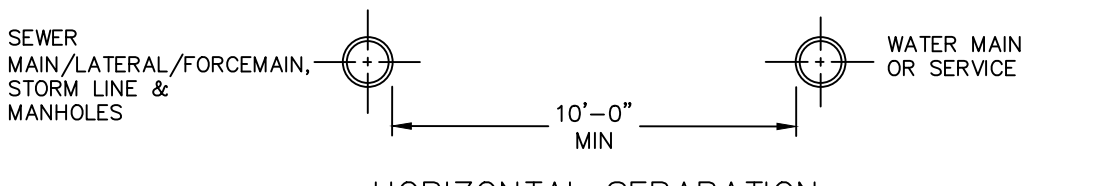

HORIZONTAL SEPARATION

- NOTE:**
- NO DEVIATION IN THE SEPARATION REQUIREMENTS WILL BE PERMITTED WITHOUT THE EXPRESS APPROVAL OF THE DUTCHESS COUNTY DEPARTMENT OF HEALTH AND THE CITY OF BEACON. CONCRETE ENCASMENT OF WATERLINE OR OFFSETTING OF WATERLINE SHALL BE REQUIRED WHERE SEPARATION DISTANCES CANNOT BE MAINTAINED.

WATER LINE SEPARATION DETAIL
NOT TO SCALE

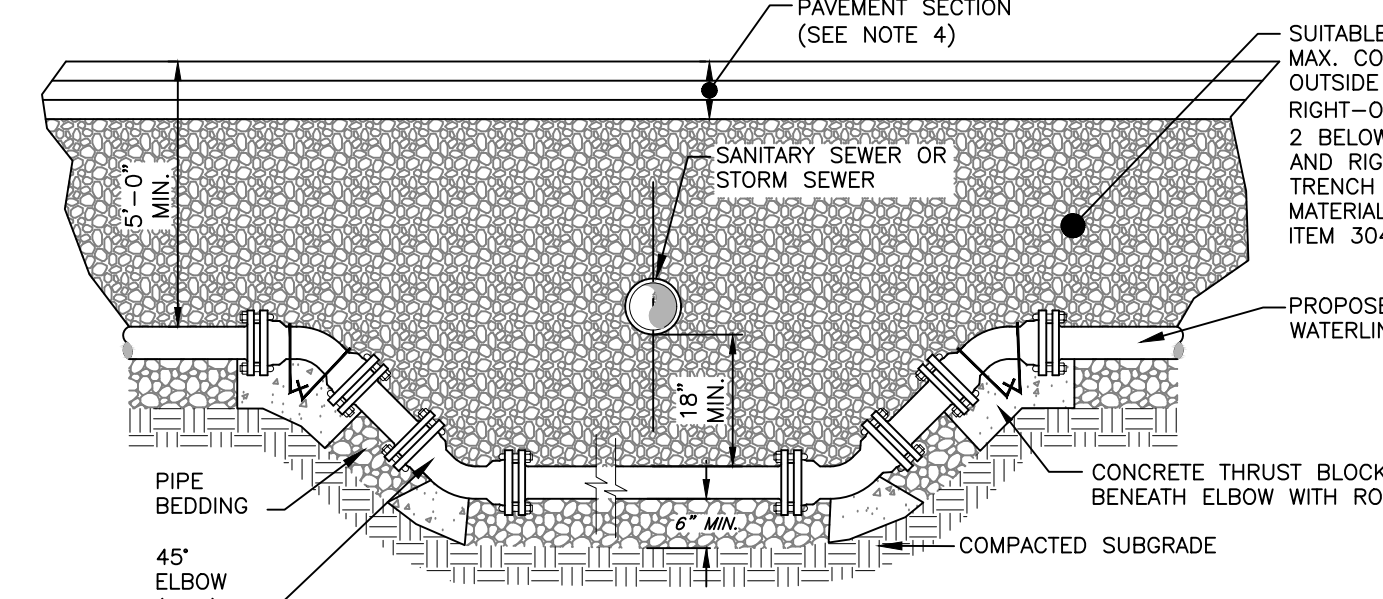

- NOTES:**
- WHEN THE ELEVATION OF THE SANITARY OR STORM SEWER CANNOT BE VARIED TO MEET THE ABOVE REQUIREMENTS, THE WATER SERVICE LINE OR MAIN SHALL BE RELOCATED TO PROVIDE THIS REQUIRED SEPARATION OR RECONSTRUCTED WITH MECHANICAL JOINT PIPE FOR A DISTANCE OF TEN (10) FEET ON EACH SIDE OF THE SEWER. ONE FULL LENGTH OF WATERMAIN SHALL BE CENTERED OVER THE SEWER SO THAT BOTH JOINTS WILL BE AS FAR AWAY FROM THE SEWER AS POSSIBLE.
 - SUITABLE RUN OF TRENCH SHALL NOT INCLUDE FROZEN MATERIALS, DEBRIS, ORGANIC MATERIALS, ENLARGED PARTICLES, LARGE STONES OR OTHER UNSUITABLE MATERIALS. IF THE RUN OF TRENCH MATERIAL IS FOUND TO BE UNSUITABLE, A SUITABLE BACKFILL MATERIAL SHALL BE IMPORTED AND USED.
 - THE RELOCATED WATER MAIN/SERVICE LINE SHALL BE DISINFECTED IN ACCORDANCE WITH AWWA, NYSDOH AND DDOH STANDARDS.
 - PAVEMENT RESTORATION SHALL BE IN ACCORDANCE WITH THE PAVEMENT RESTORATION DETAIL.
 - ALL REPLACED WATERMAIN SHALL BE 12" CLASS 52 DUCTILE IRON.

WATER LINE OFFSET DETAIL
NOT TO SCALE

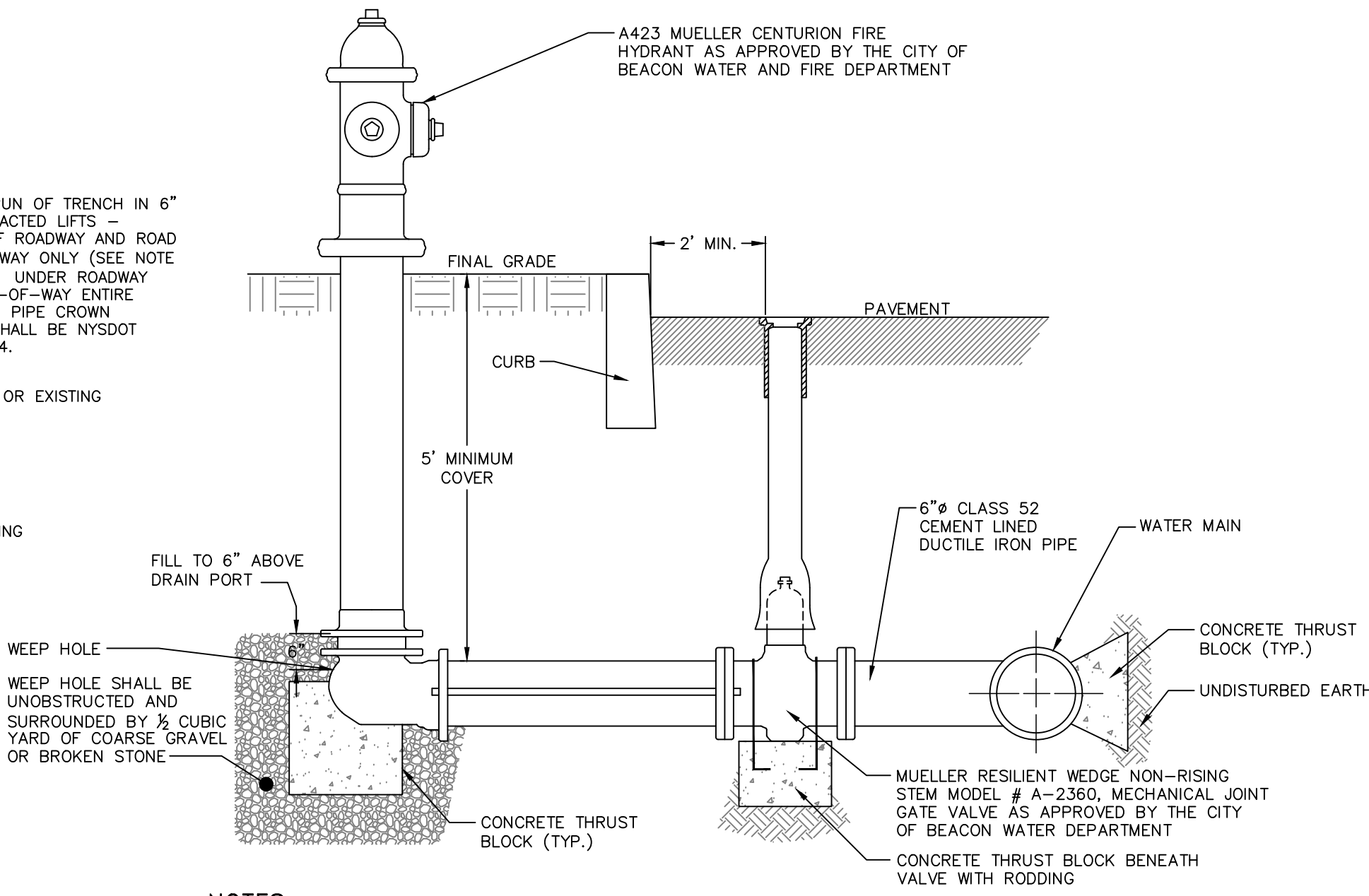

- NOTES:**
- THE GATE VALVE SHALL BE LOCATED THIRTY SIX (36) INCHES FROM THE HYDRANT CENTER LINE.
 - 1/2" STEEL TIE RODS TO BE PROVIDED BETWEEN THE GATE VALVE AND THE HYDRANT.

HYDRANT DETAIL
NOT TO SCALE

WATER NOTES:

- THE PROPOSED APARTMENT BUILDINGS ARE TO BE SERVED BY THE CITY OF BEACON MUNICIPAL WATER SYSTEM. INSTALLATION OF ALL COMPONENTS SHALL BE PERFORMED IN ACCORDANCE WITH THE REQUIREMENTS OF THE CITY CODE, CHAPTER 219.
- REFER TO THE DUTCHESS COUNTY DEPARTMENT OF HEALTH STANDARD NOTES FOR ADDITIONAL PERTINENT INFORMATION.
- THE WATER MAIN SHALL BE INSTALLED, PRESSURE TESTED AND LEAKAGE TESTED IN ACCORDANCE WITH THE LATEST EDITION OF AWWA C600 (SEE NOTES BELOW).
- THE DUTCHESS COUNTY DEPARTMENT OF HEALTH, CITY OF BEACON WATER OPERATOR, AND THE CERTIFYING PROFESSIONAL ENGINEER SHALL BE NOTIFIED PRIOR TO COMMENCEMENT OF THE WATER MAIN INSTALLATION.
- THE WATER MAIN SHALL BE DISINFECTED IN ACCORDANCE WITH THE LATEST EDITION OF AWWA C651 (SEE NOTES BELOW).
- WATER MAIN MATERIAL SHALL BE CLASS 52 CEMENT LINED DUCTILE IRON PIPE WITH MECHANICAL JOINTS AND SHALL MEET THE REQUIREMENTS OF AWWA C150 AND ANSI A21.51.
- MEGALUG RESTRAINING SYSTEMS SHALL BE USED AT ALL FITTINGS, VALVES AND HYDRANTS (SEE SCHEDULE ON SHEET 14).
- GATE VALVES SHALL BE MUELLER RESILIENT WEDGE, NON-RISING STEM, MECHANICAL JOINT.
- HYDRANTS SHALL BE A-423 MUELLER CENTURION, WITH A MUELLER GATE VALVE BEFORE THE HYDRANT.
- SERVICE LINES SHALL BE 3/4" COPPER K, UNLESS OTHERWISE NOTED ON THE PLAN.
- THE CONTRACTOR SHALL VERIFY THE EXISTING WATER MAIN MATERIAL AND BE PREPARED TO PROVIDE A SPECIAL COUPLING FOR CONNECTION OF THE PROPOSED DUCTILE IRON WATER MAIN.
- A PRESSURE REDUCING VALVE SHALL BE INSTALLED FOR EACH NEW TOWNHOME, WATTS MODEL 25AUB-23 OR EQUAL AS APPROVED BY THE CITY OF BEACON WATER DEPARTMENT.
- THE CITY OF BEACON SHALL OWN, OPERATE AND MAINTAIN THE WATER MAIN THROUGHOUT THE SITE, INCLUDING ALL APPURTENANCES.
- THE HOA OR OWNER SHALL ANNUALLY EXERCISE ALL WATER VALVES.

WATER MAIN PRESSURE & LEAKAGE TESTING

- GENERAL: ALL PIPING SHALL BE TESTED IN ACCORDANCE WITH THE REQUIREMENTS OF THE LATEST EDITION OF AWWA C600, EXCEPT AS ADDED OR AMENDED BELOW.
- THE CONTRACTOR SHALL FURNISH ALL LABOR, MATERIALS AND EQUIPMENT NECESSARY FOR ANY AND ALL REQUIRED PIPE TAPS FOR TESTING, AND AS NECESSARY FOR TESTING AS SPECIFIED. EQUIPMENT WILL BE SUCH THAT THE ENGINEER MAY INSTALL HIS OWN PRESSURE GAUGE.
 - A PRESSURE TEST AND LEAKAGE TEST ARE REQUIRED FOR ALL PIPE.
 - TESTING TO BE PERFORMED ONLY AFTER PARTIAL OR COMPLETE BACKFILL AND RESTRAINT BLOCKING (USING HIGH EARLY CEMENT) HAS HAD 7 DAYS TO CURE.
 - THE MAIN SHALL BE PARTIALLY BACKFILLED OR BRACED AGAINST MOVEMENT DURING THE TEST. ALL AIR MUST BE BLED OUT OF THE SECTION TO BE TESTED. IF NECESSARY, CONTRACTOR SHALL INSTALL CORPORATION STOPS AT THE HIGH POINTS, FOR BLOW-OFFS. AFTER ALL AIR HAS BEEN EXPELLED, THE CORPORATION COCKS SHALL BE CLOSED AND THE PRESSURE TEST APPLIED. AFTER EXAMINATION OF EXPOSED PARTS OF THE SYSTEM, THE TEST PRESSURE SHALL BE INCREASED TO 1 1/2 TIMES THE NORMAL PRESSURE, BASED UPON THE ELEVATION OF THE LOWEST POINT IN THE LINE OR SECTION UNDER THE TEST, BUT SUCH PRESSURE SHALL NOT BE LESS THAN 150 PSI NOR MORE THAN 200 PSI, AND EXPOSED PARTS AGAIN EXAMINED. THE MINIMUM DURATION OF THE LEAKAGE TEST SHALL BE TWO (2) HOURS.
 - ALLOWABLE SYSTEM LEAKAGE AS SPECIFIED IN THE REFERENCED STANDARDS. IF LEAKAGE IN SYSTEM IS GREATER THAN ALLOWABLE, CONTRACTOR WILL LOCATE AND REPAIR SYSTEM AT HIS EXPENSE AND RETEST, CONTINUE TO TEST AND REPAIR THE SYSTEM UNTIL LEAKAGE IS WITHIN ACCEPTABLE LIMITS.
 - NO DUCTILE IRON PIPE INSTALLATION WILL BE ACCEPTED IF THE LEAKAGE IS GREATER THAN THAT DETERMINED BY THE FOLLOWING FORMULA:

$$L = \frac{SD^3P}{748,000}$$
 WHERE
 L = LEAKAGE IN GALLONS PER HOUR
 S = LENGTH OF PIPE TESTED, IN FEET
 D = NOMINAL DIAMETER OF PIPE IN INCHES
 P = AVERAGE TEST PRESSURE DURING LEAKAGE TEST, IN PSI (GAUGE)

WATER MAIN DISINFECTION & TESTING

- THE CONTRACTOR SHALL NOTIFY THE CITY OF BEACON WATER DEPARTMENT PRIOR TO TESTING AND SHALL ALSO COORDINATE HIS ACTIONS WITH THE CITY ENGINEER SO AS TO AVOID UNDUE DISTURBANCE OF THE WATER SUPPLY TO ANY EXISTING USERS.
- THE CONTRACTOR SHALL INFORM THE DESIGN ENGINEER'S AND CITY ENGINEER'S OFFICE A MINIMUM OF 24 HOURS PRIOR TO TESTING SUCH THAT WITNESSING CAN TAKE PLACE AND PROPER CERTIFICATIONS CAN BE ISSUED.
- ALL NEWLY INSTALLED WATER MAINS SHALL BE FLUSHED AT A MINIMUM VELOCITY OF 2.5 FT/SECOND BEFORE AND AFTER DISINFECTION.
- ALL WATER LINES SHALL BE DISINFECTED USING THE PROCEDURES DESCRIBED IN THE LATEST EDITION OF AWWA C651 SPECIFICATIONS FOR DISINFECTION OF WATER LINES (WITH THE EXCEPTION OF THE TABLET METHOD). WATER ENTERING THE NEW MAIN SHALL RECEIVE A DOSE OF CHLORINE FED AT A CONSTANT RATE SUCH THAT THE WATER WILL HAVE NOT LESS THAN 25 MG/L FREE CHLORINE. CHLORINE APPLICATION SHALL NOT CEASE UNTIL THE ENTIRE MAIN IS FILLED WITH HEAVILY CHLORINATED WATER.
- DISINFECTED WATER SHALL REMAIN IN THE NEWLY INSTALLED WATER LINE FOR A MINIMUM OF 24 HOURS. AFTER THIS RETENTION PERIOD, THE HEAVILY CHLORINATED WATER SHALL BE FLUSHED FROM THE MAIN UNTIL CHLORINE MEASUREMENTS SHOW A CONCENTRATION IN THE WATER LEAVING THE MAIN HAS NO HIGHER THAN THAT GENERALLY PREVAILING IN THE SYSTEM. AT SUCH TIME, BACTERIOLOGICAL SAMPLING FOR SUBMITTAL TO STATE HEALTH LABORATORIES SHALL BE PERFORMED BY THE CONTRACTOR.
- WATER SAMPLES SHALL BE TESTED FOR TOTAL COLIFORM, TPC (HETEROTROPHIC PLATE COUNT), TURBIDITY & COLOR.
- CONTRACTOR WILL CONTINUE FLUSHING AND DISINFECTION OPERATION UNTIL ACCEPTABLE BACTERIOLOGICAL RESULTS ARE OBTAINED. TWO (2) SUCCESSIVE SAMPLES ARE TO BE TAKEN AT TWENTY-FOUR (24) HOUR INTERVALS.
- THE ENVIRONMENT INTO WHICH THE HEAVILY CHLORINATED WATER IS TO BE DISCHARGED SHALL BE INSPECTED, AND IF THERE IS ANY LIKELIHOOD THAT THE CHLORINATED DISCHARGE WILL CAUSE DAMAGE, THEN A REDUCING AGENT SHALL BE APPLIED TO THE WATER TO BE WASTED TO THOROUGHLY NEUTRALIZE THE CHLORINE RESIDUAL IN THE WATER. PERMITS MAY BE REQUIRED. THE CITY ENGINEER SHALL BE NOTIFIED PRIOR TO DISPOSAL OF HIGHLY CHLORINATED WATER.

DRAWN BY: CMB				CHECKED BY: MAB			
REVISIONS:				REVISIONS:			
NO.	DATE	DESCRIPTION	BY	NO.	DATE	DESCRIPTION	BY
2	3/26/19	ADDED SHEET	CMB				
3	4/30/19	PER PLANNING BOARD COMMENTS	CMB				



HUDSON LAND DESIGN
PROFESSIONAL ENGINEERING P.C.
 174 MAIN ST., BEACON, NEW YORK 12508
 13 CHAMBERS ST., NEWBURGH, NEW YORK 12550
 PH: 845-440-6926
 F: 845-440-6637

WATER DETAILS
53 ELIZA STREET
 53 ELIZA STREET
 CITY OF BEACON
 DUTCHESS COUNTY, NEW YORK
 TAX ID: 6054-29-031870

JOB #: 2018:032
DATE: 8/28/18
SCALE: AS NOTED
TITLE: CD-3
SHEET: 12 OF 13